

## Datasheet

Subject to technical alteration  
Issue date: 24.08.2015



## Application

The room operating panel is designed for temperature detection and integrated manual control of HVAC applications (change Set point, change Occupancy, change Fan Speed).

## Types Available

WRF04 P Sensor	room sensor with set point potentiometer (P) and sensor*
WRF04 PTD Sensor	room sensor with set point potentiometer (P), push button (T), status LED (D) and sensor *
WRF04 PST Sensor	room sensor with set point potentiometer (P), rotary switch (S), push button (T) and sensor *
WRF04 PSTD Sensor	set point potentiometer (P), rotary switch (S), presence button (T) and status-LED and sensor (D)

\*eg: PT100/PT1000/Ni1000/Ni1000TK5000/LM235Z/NTC.../PTC... and other sensors on request

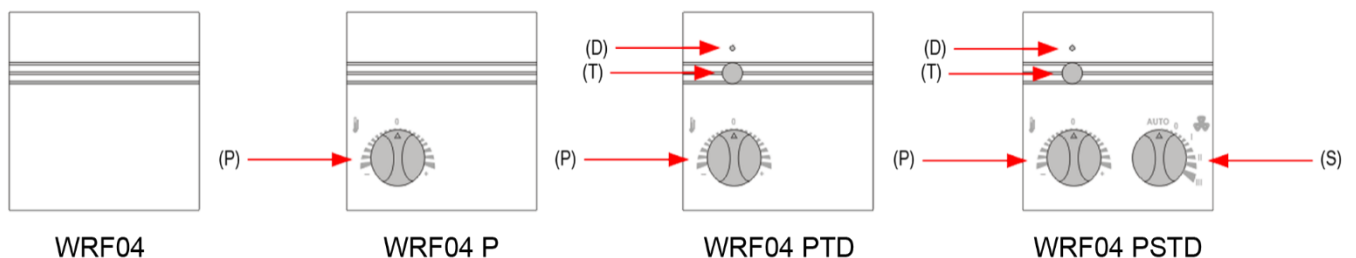

## Security Advice – Caution



The installation and assembly of electrical equipment should only be performed by authorized personnel.

The product should only be used for the intended application. Unauthorised modifications are prohibited! The product must not be used in relation with any equipment that in case of a failure may threaten, directly or indirectly, human health or life or result in danger to human beings, animals or assets. Ensure all power is disconnected before installing. Do not connect to live/operating equipment.

**CAUTION! Risk of electric shock due to live components within the enclosure, especially devices with mains voltage supply (usually between 90..265 V).**

Please comply with

- Local laws, health & safety regulations, technical standards and regulations
- Condition of the device at the time of installation, to ensure safe installation
- This data sheet and installation manual
  - The devices technical data and installation manual.



## Notes on Disposal

As a component of a large-scale fixed installation, Thermokon products are intended to be used permanently as part of a building or a structure at a pre-defined and dedicated location, hence the Waste Electrical and Electronic Act (WEEE) is not applicable. However, most of the products may contain valuable materials that should be recycled and not disposed of as domestic waste. Please note the relevant regulations for local disposal.

## Remarks to Room Sensors

### Location and Accuracy of Room Sensors

The room sensor should be mounted in a suitable location for measuring accurate room temperature. The accuracy of the temperature measurement also depends directly on the temperature dynamics of the wall. It is important, that the back plate is completely flush to the wall so that there is sufficient circulation of air through the vents in the cover, otherwise, deviations in temperature measurement will occur due to uncontrolled air circulation. The temperature sensor should not be covered by furniture or other objects. Mounting next to doors (due to draught) or windows (due to colder outside wall) should be avoided.

### Surface and Flush Mounting

The measuring result is influenced by the thermal characteristics of the wall. A solid concrete wall responds to thermal fluctuations within a room in a much slower than a light-weight structure wall. Room temperature sensors installed in flush-mounted boxes have a longer response time to thermal variations. In extreme cases they detect the radiant heat of the wall even if the air temperature in the room is lower for example. The quicker the dynamics of the wall (temperature acceptance of the wall) or the longer the selected inquiry interval of the temperature sensor is the smaller the deviations limited in time are.

## Build-up of Self-Heating by Electrical Dissipative Power

Temperature sensors with electronic components always have a dissipative power, which affects the temperature measurement of the ambient air. The dissipation in active temperature sensors shows a linear increase with rising operating voltage. This dissipative power has to be considered when measuring temperature. In case of a fixed operating voltage ( $\pm 0,2$  V) this is normally done by adding or reducing a constant offset value. As Thermokon transducers work with a variable operating voltage, only one operating voltage can be taken into consideration, for reasons of production engineering. Transducers 0..10 V / 4..20 mA have a standard setting at an operating voltage of 24 V =. That means, that at this voltage, the expected measuring error of the output signal will be the least. For other operating voltages, the offset error will be increased by a changing power loss of the sensor electronics. If a re-calibration should become necessary later directly on the sensor, this can be done by means of a trimming potentiometer on the sensor board.

**Remark: Occurring draft leads to a better carrying-off of dissipative power at the sensor. Thus temporally limited fluctuations might occur upon temperature measurement.**

## Technical Data

Measuring values		temperature
Output voltage	passive TRV	depending on used sensor 1x 0..10 V, min. load 5 k $\Omega$
Power supply		15..24 V = ( $\pm 10\%$ ) or 24 V~ ( $\pm 10\%$ )
Power consumption		typ. 0,42 W (24 V =)   0,84 VA (24 V ~)
Measuring range temp	passive TRV3	depending on used sensor 0..+50 °C
Accuracy temperature	passive	depending on used sensor $\pm 1\%$ of measuring range (typ. at 21 °C)
Inputs		2 inputs for floating contacts
Set point (P)		set point adjustment, 3-wire, default values 1 k $\Omega$ , 5 k $\Omega$ or 10 k $\Omega$
	optional	active output 0..10 V
Rotary switch (S)		fancoil (max. 5 stages), 2-stages (0,I), 3-stages (0,I,II), 4-stages (0,I,II,III) or 5-stages (Auto,0, I, II, III), switching capacity max. 5 W
Button (T)		occupancy signal, 2-wire, switching capacity max. 600 mW
LED (D)		status feedback, 2-wire, more LED's available, colour green, red or yellow
Labelling	rotary switch set point	0,I or 0,I,II or 0,I,II,III or Auto,0,I,II,III -,0,+
Enclosure		PC, pure white
Protection		IP30 according to EN 60529
Cable entry		breaking points top/bottom, rear entry
Connection electrical		terminal block max. 1,5mm <sup>2</sup>
Ambient condition		-35..+70 °C, max. 85% rH non-condensing
Weight		50 g
Mounting		flush mounted with standard EU box ( $\varnothing=55$ mm) to be mounted flat onto the surface using adhesive foil or screws
Notes		custom colours, labelling and operating elements on request, other sensors on request

## Mounting Advices

The device may be installed in a voltage free condition only.

The device can be installed on a flush-mounted box or directly onto the wall.

If installed on a flush-mounted box, seal the pipe to eliminate drafts.

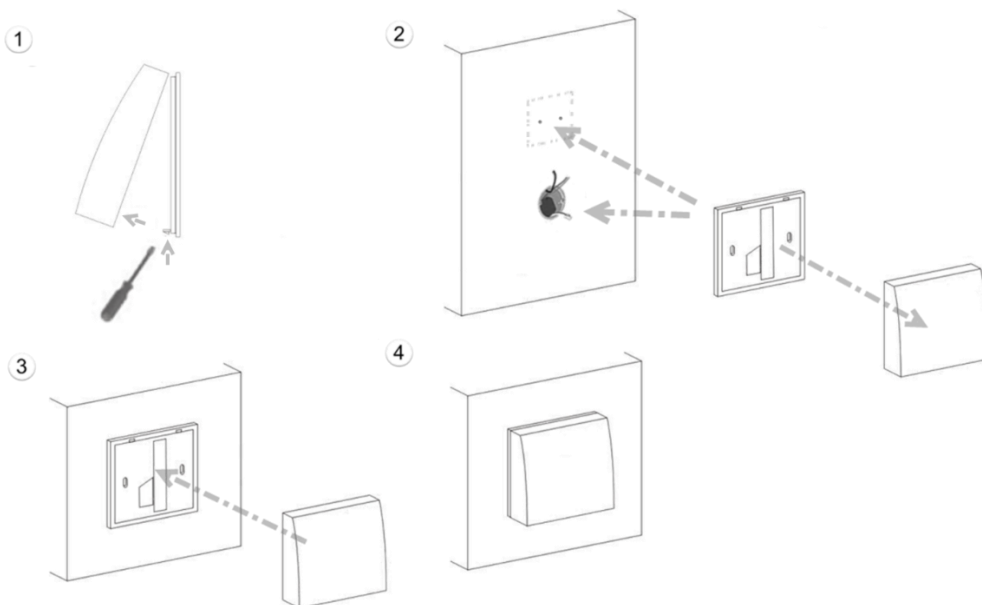

## Connection Plan

The terminal assignments vary depending on the type of the device. Terminal plan is attached to the device. The standard terminal assignment follows the connection plan below.

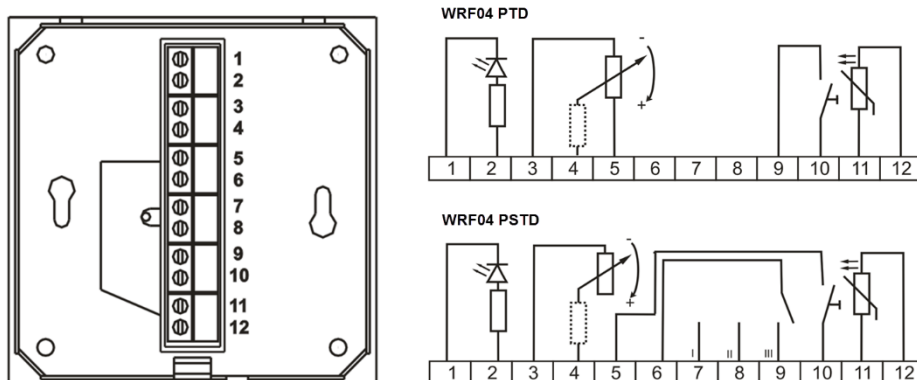

## Dimensions (mm)

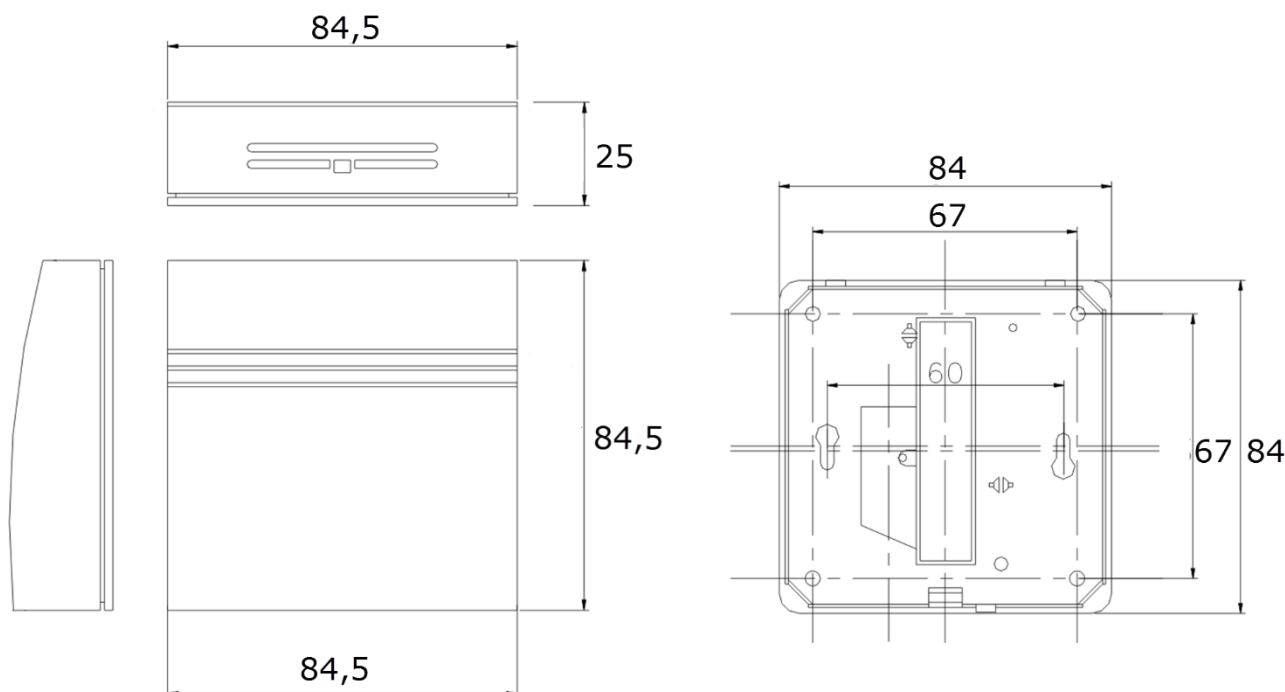

## Accessories

Rawl plugs and screws (2 pcs. each)	Item No. 102209
Frame for surface mounting WRF04	Item No. 111584
Balls stroke protection BS100 (only for WRF04)	Item No. 103312