

Datasheet

Subject to technical alteration
Issue date: 28.07.2017



Application

Duct averaging temperature sensor in enclosure USE-M for measuring the average temperature in air ducts. The sensor detects the applied temperature value throughout the entire length.

Types Available

Duct averaging sensor with Display temperature – active RS485 Modbus

MWF+ LCD RS485 Modbus L<x> incl. Installation kit

<x>: sensor rod length 3000/6000 mm

Security Advice – Caution



The installation and assembly of electrical equipment should only be performed by authorized personnel.

The product should only be used for the intended application. Unauthorised modifications are prohibited! The product must not be used in relation with any equipment that in case of a failure may threaten, directly or indirectly, human health or life or result in danger to human beings, animals or assets. Ensure all power is disconnected before installing. Do not connect to live/operating equipment.

Please comply with

- Local laws, health & safety regulations, technical standards and regulations
- Condition of the device at the time of installation, to ensure safe installation
- This data sheet and installation manual

Notes on Disposal



As a component of a large-scale fixed installation, Thermokon products are intended to be used permanently as part of a building or a structure at a pre-defined and dedicated location, hence the Waste Electrical and Electronic Act (WEEE) is not applicable. However, most of the products may contain valuable materials that should be recycled and not disposed of as domestic waste. Please note the relevant regulations for local disposal.

Build-up of Self-Heating by Electrical Dissipative Power

Temperature sensors with electronic components always have a dissipative power, which affects the temperature measurement of the ambient air. The dissipation in active temperature sensors shows a linear increase with rising operating voltage. This dissipative power has to be considered when measuring temperature. In case of a fixed operating voltage ($\pm 0,2$ V) this is normally done by adding or reducing a constant offset value. As Thermokon transducers work with a variable operating voltage, only one operating voltage can be taken into consideration, for reasons of production engineering. Transducers 0..10 V / 4..20 mA have a standard setting at an operating voltage of 24 V =. That means, that at this voltage, the expected measuring error of the output signal will be the least. For other operating voltages, the offset error will be increased by a changing power loss of the sensor electronics. If a re-calibration should become necessary later directly on the sensor, this can be done by means of a trimming potentiometer on the sensor board.

Remark: Occurring draft leads to a better carrying-off of dissipative power at the sensor. Thus temporally limited fluctuations might occur upon temperature measurement.

Technical Data

Measuring values	temperature
Output voltage	0..10 V or 0..5 V, min load 10k Ω (live-zero configuration via Thermokon USEapp)
Network technology	RS485 Modbus
Power supply	15..35 V = or 19..29 V ~,
Power consumption	max. 2,5 W (24 V =) max. 4,3 VA (24 V ~)
Measuring range temp.	-20..+80 °C (default setting), optionally configured via Thermokon USEapp
Accuracy temperature	$\pm 0,5$ K (typ. at 21 °C)
Display	LCD 1.14x1.38 in. with RGB backlight
Enclosure	enclosure USE-M, PC, pure white, cover PC, transparent, with removable cable entry
Protection	IP65 according to EN 60529
Cable entry	M25 for cable max. $\varnothing=7$ mm, seal insert for fourfold cable entry
Connection electrical	removable plug-in terminal, max. 2,5 mm ² removable plug-in terminal, max. 1,5 mm ²
	Modbus clamp
Sensor rod	3000 mm, 6000 mm
Ambient condition	enclosure -35..+70 °C, max. 85% rH short term condensation

Mounting Advices

Model MWF can either be mounted directly on the ventilation duct by means of a mounting flange or by screws.

By means of the mounting brackets included the sensor rod is braced to the ventilation duct.

Note: Please pay attention to the sensor rod while mounting and protect it from mechanical damage!

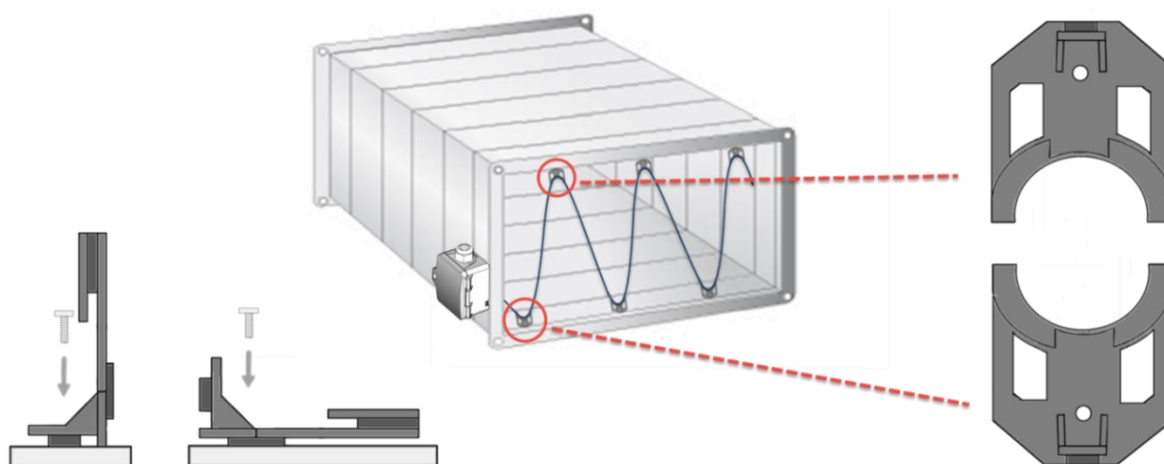

Vertical mounting Horizontal mounting

Connection Plan

To change the output voltage range (default 0..10 V to 0..5 V) via jumper, the display must be removed from the board first. If the RS485 cable is looped through, connect both cable shields using the enclosed 2-pol. Connect terminal as shown.

MWF+ RS485 Modbus

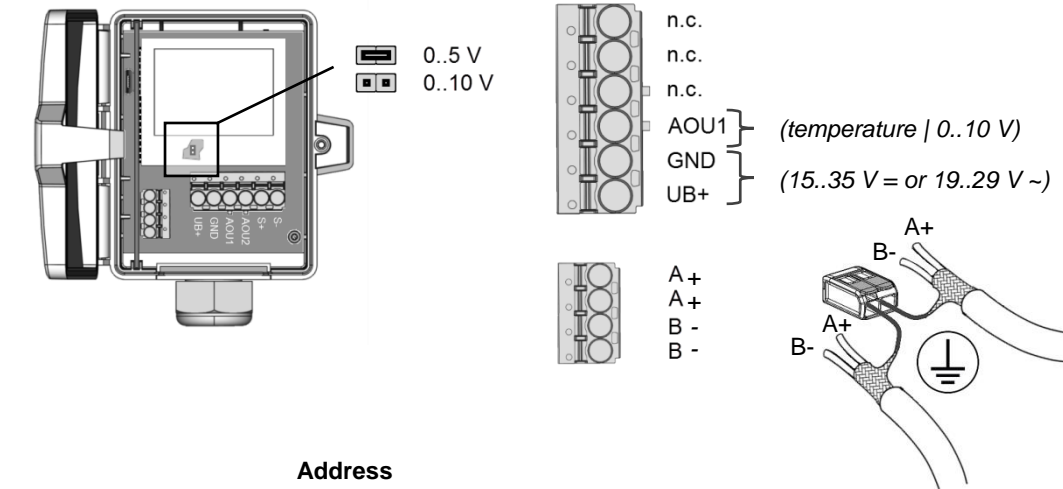

Address

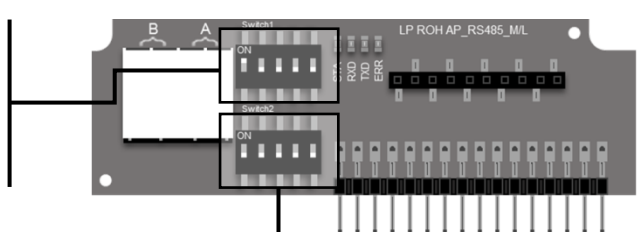
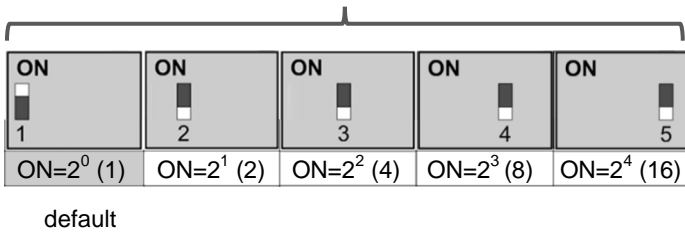

Termination 120Ω

Baud rate

Parity

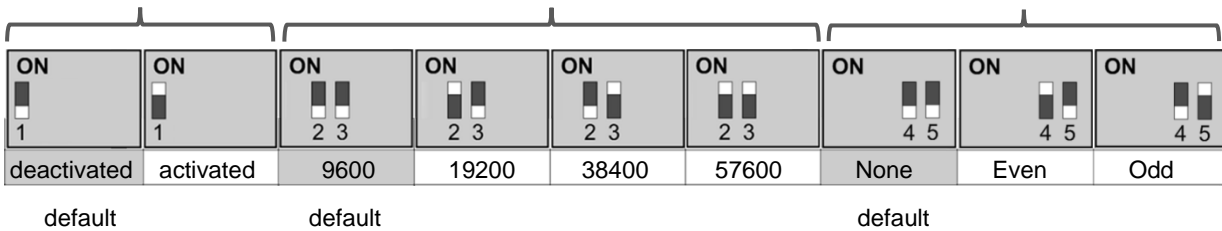

Register 400 = 1 (unit SI)

Address	Access	Description	Resolution / Unit		
0	R	Temperatur	SI	0.1	°C

Register 400 = 2 (unit Imperial)

Address	Access	Description	Resolution / Unit		
0	R	Temperatur	Imperial	0.1	°F

The modbus address of the device is set in the range of 1 ... 31 (binary encoded) using a 5-pole DIP switch. With address 0 via DIP, an extended address range (32..247) is available via USEapp.



Modbus addresses:

USE-RS485 Modbus Interface

A detailed description of the Modbus addresses can be found under the following link:

→ [Download](#)

Configuration



The Thermokon bluetooth dongle with micro-USB is required for communication between USEapp and USE-M / USE L (Item No.: 668262). Commercial bluetooth dongles are not compatible.

Application-specific reconfiguration of the devices can be carried out using the Thermokon USEapp. The configuration is carried out in the voltage-supplied state.



The configuration-app and the app description can be found in the download area of our webpage.

→ [Download \(APK-file for Android\)](#)

Dimensions (mm)

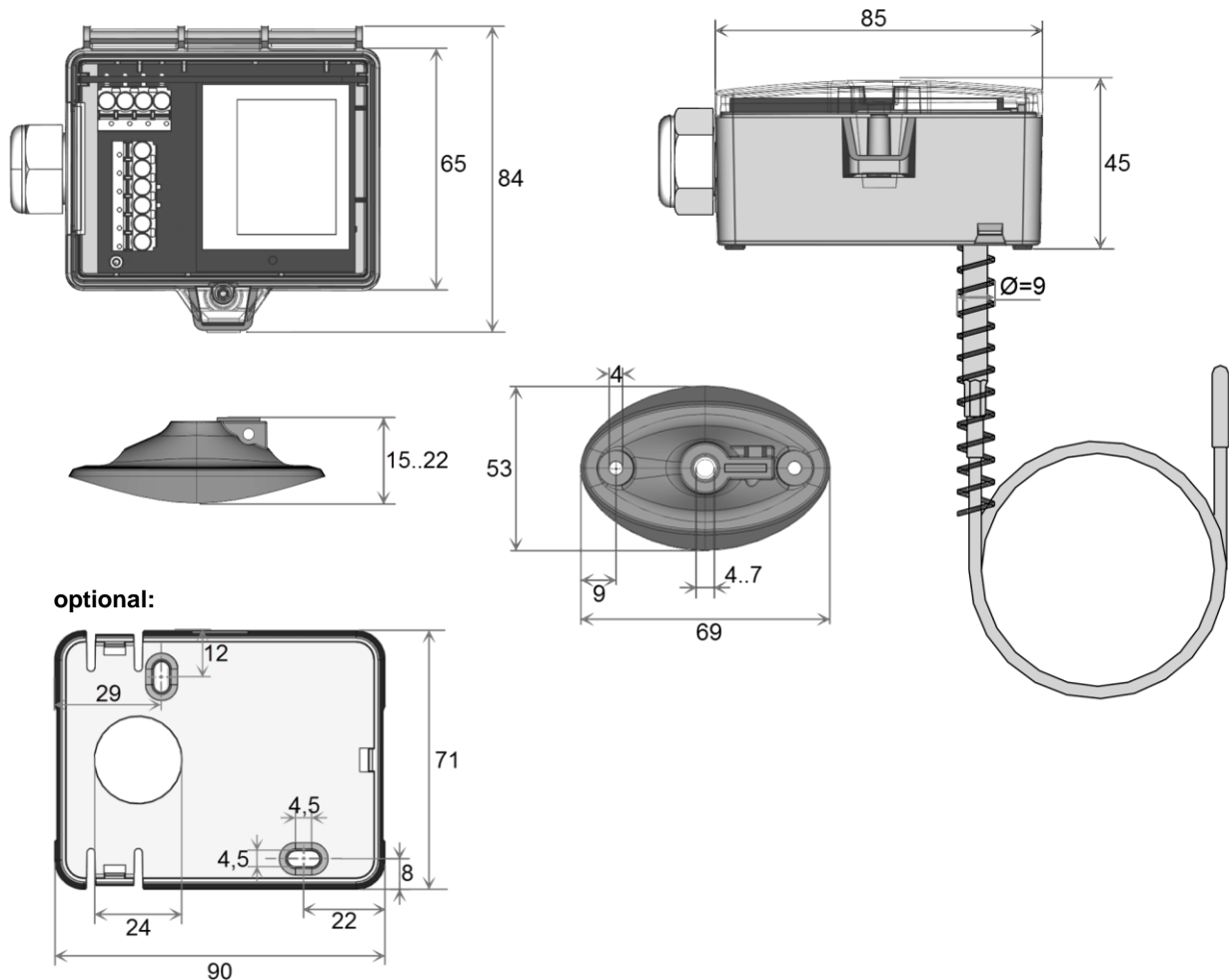

Accessories (included in delivery)

Mounting angle set	Item No. 458399
Mounting flange MF6 flexible (incl. inserts for $\varnothing=4$ 6 7 mm)	Item No. 399098
Mounting kit 2	Item No. 640503
• Cable entry M16 • Cover screw • 2 Screws (rounded head)	

Accessories (optional)

Bluetooth dongle	Item No. 668262
Cable entry M25 USE white, sealing insert 4x $\varnothing=0.28$ in. (4 pcs)	Item No. 641364
Mounting base	Item No. 631228

Thermowell pockets stainless steel / brass for sensors with pocket $\varnothing=6$ mm

length	50 mm	100 mm	150 mm	200 mm	250 mm	300 mm	450 mm
THMSDS	610995	611008	611015	611022	611763	611039	611046
THVADS	611152	611817	611824	611848	611862	611879	611893

MS-thermowell pocket (brass, suitable up to 16 bar) type THMSDS <xx>.

VA-thermowell pocket (stainless steel, suitable up to 40 bar) type THVADS <xx>.