

LK+ VOC RS485 Modbus

Duct sensor for air quality, temperature and humidity (optional)

thermokon[®]
HOME OF SENSOR TECHNOLOGY

Datasheet

Subject to technical alteration
Issue date: 23.06.2017



Application

Duct air quality sensor for detection of VOC air quality, and optional humidity combined in one unit. Designed for duct mounted applications with 2 0..10 V outputs. The sensor consists of a transmitter with VOC sensor, based on a heated tin oxide semiconductor.

Types Available

Duct sensor VOC + temp – active BUS

LK+ VOC Temp RS485 Modbus

Duct sensor VOC + temp +rH – active BUS

LK+ VOC Temp_rH RS485 Modbus

Options: additional passive temperature sensor
eg: PT100/PT1000/Ni1000/Ni1000TK5000/NTC10K... and other sensors on request.

Security Advice – Caution



The installation and assembly of electrical equipment should only be performed by authorized personnel.

The product should only be used for the intended application. Unauthorised modifications are prohibited! The product must not be used in relation with any equipment that in case of a failure may threaten, directly or indirectly, human health or life or result in danger to human beings, animals or assets. Ensure all power is disconnected before installing. Do not connect to live/operating equipment.

Please comply with

- Local laws, health & safety regulations, technical standards and regulations
- Condition of the device at the time of installation, to ensure safe installation
- This data sheet and installation manual

Notes on Disposal



As a component of a large-scale fixed installation, Thermokon products are intended to be used permanently as part of a building or a structure at a pre-defined and dedicated location, hence the Waste Electrical and Electronic Act (WEEE) is not applicable. However, most of the products may contain valuable materials that should be recycled and not disposed of as domestic waste. Please note the relevant regulations for local disposal.

Build-up of Self-Heating by Electrical Dissipative Power

Temperature sensors with electronic components always have a dissipative power, which affects the temperature measurement of the ambient air. The dissipation in active temperature sensors shows a linear increase with rising operating voltage. This dissipative power has to be considered when measuring temperature. In case of a fixed operating voltage ($\pm 0,2$ V) this is normally done by adding or reducing a constant offset value. As Thermokon transducers work with a variable operating voltage, only one operating voltage can be taken into consideration, for reasons of production engineering. Transducers 0..10 V / 4..20 mA have a standard setting at an operating voltage of 24 V =. That means, that at this voltage, the expected measuring error of the output signal will be the least. For other operating voltages, the offset error will be increased by a changing power loss of the sensor electronics. If a re-calibration should become necessary later directly on the sensor, this can be done by means of a trimming potentiometer on the sensor board.

Remark: Occurring draft leads to a better carrying-off of dissipative power at the sensor. Thus temporally limited fluctuations might occur upon temperature measurement.

Technical Data

| | | |
|--------------------------|--------------|---|
| Measuring values | Temp_rH | VOC, temperature + humidity (depending on the device) |
| Output voltage | | 2x 0..10 V or 0..5 V, min. load 10 k Ω (live-zero configuration via Thermokon USEapp) |
| Network technology | | RS485 Modbus |
| Power supply | | 15..35 V = or 19..29 V ~ |
| Power consumption | | max. 2,3 W (24 V =) max. 4,3 VA (24 V ~) |
| Measuring range temp. | | 0..+50 °C (default setting), optionally configured via Thermokon USEapp |
| Measuring range humidity | Temp_rH | 0..100% rH non-condensing, optionally configured via Thermokon USEapp (enthalpy, absolute humidity, dew point) |
| Accuracy temperature | passive | $\pm 0,5$ K (typ. at 21 °C) |
| Accuracy humidity | Temp_rH | typ. $\pm 0,3$ K (typ. at 21 °C), depending on used sensor |
| Air speed | | $\pm 2\%$ between 10..90% rH (typ. at 21 °C) |
| Calibration | | min. 0,3 m/s, max. 12 m/s |
| Sensor | | self-calibration |
| Enclosure | | VOC sensor (heated metal oxide semiconductor) |
| Protection | | enclosure USE-M, PC, pure white, with removeable cable entry |
| Cable entry | | IP65 according to EN 60529 |
| Connection electrical | Modbus clamp | M25, for wire max. $\varnothing=7$ mm, seal insert for fourfold cable entry |
| Pipe | | removeable plug-in terminal, max. 2,5 mm ² |
| Ambient condition | | removeable plug-in terminal, max. 1,5 mm ² |
| Mounting | | PA6, black, $\varnothing=19,5$ mm, length 180 mm |
| | | 0..+50 °C, max. 85% rH short term condensation |
| | | installation is also possible using mounting base |

Mounting Advices

The sensor can be mounted on the ventilation duct by means of the mounting flange MF20 TPO (optional with mounting base). Align the openings on the sensor tube according to the flow direction

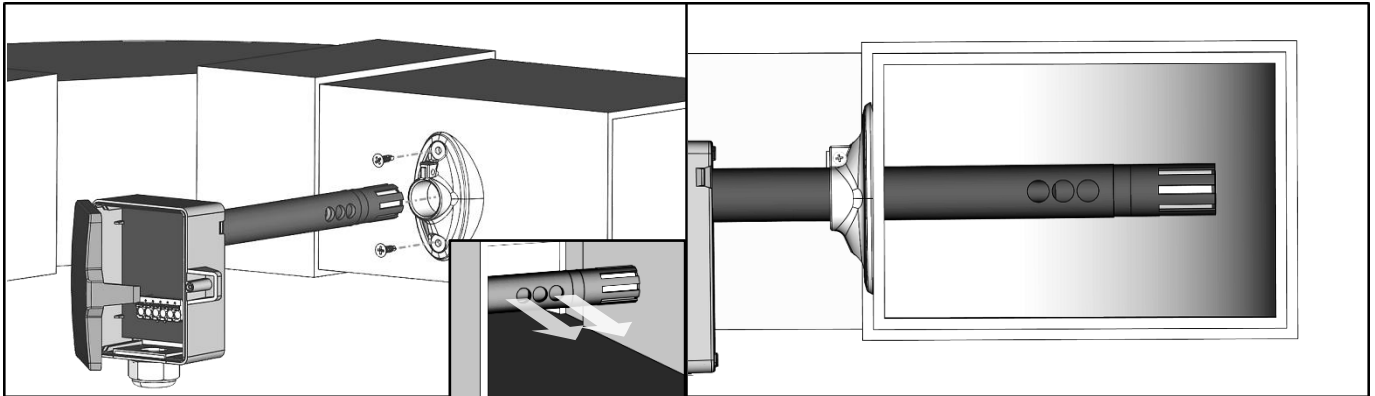

optional:

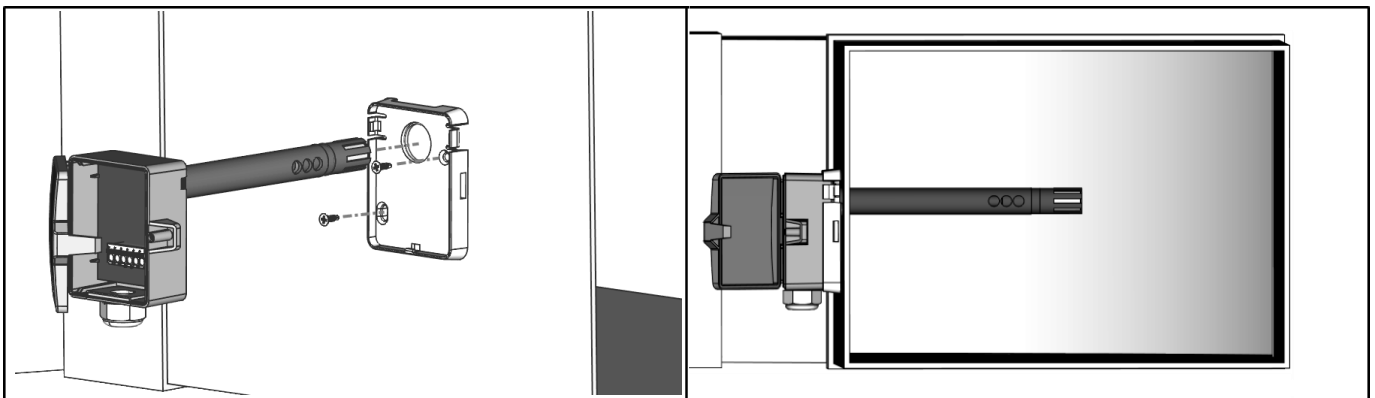

Connection Plan

If the RS485 cable is looped through, connect both cable shields using the enclosed 2-pol. Connect terminal as shown.

LK+ VOC RS485 Modbus

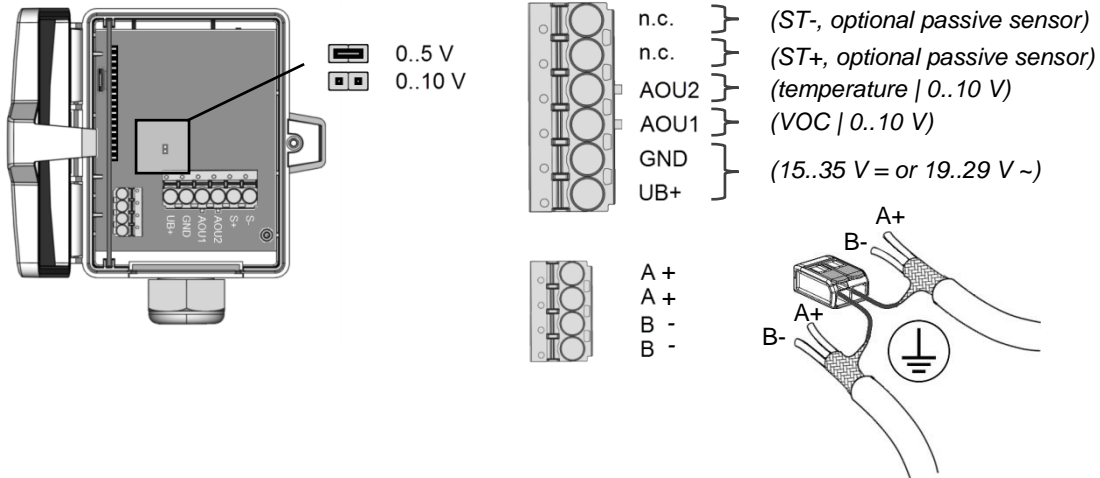

The modbus address of the device is set in the range of 1 ... 31 (binary encoded) using a 5-pole DIP switch. With address 0 via DIP, an extended address range (32..247) is available via USEapp.



Modbus addresses:

USE-RS485 Modbus Interface

A detailed description of the Modbus addresses can be found under the following link:

→ [Download](#)

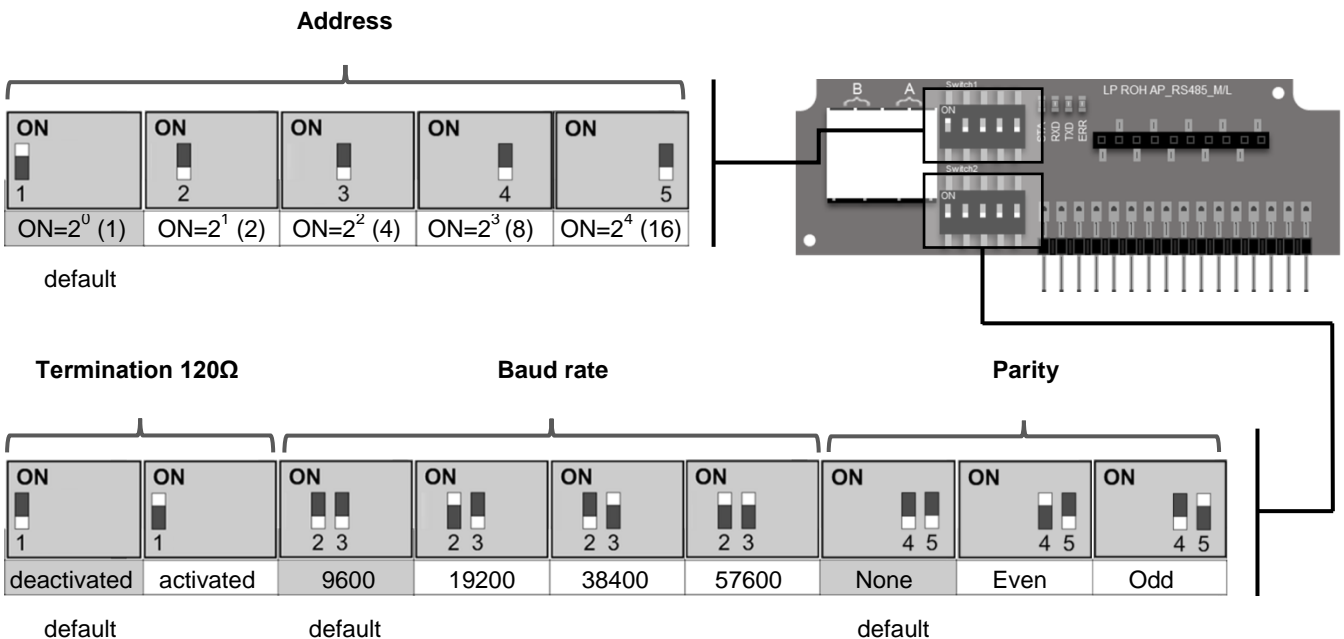

Configuration

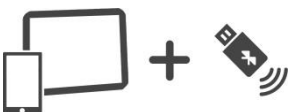

The Thermokon bluetooth dongle with micro-USB is required for communication between USEapp and USE-M / USE L (Item No.: 668262). Commercial bluetooth dongles are not compatible.

Application-specific reconfiguration of the devices can be carried out using the Thermokon USEapp. The configuration is carried out in the voltage-supplied state.



The configuration-app and the app description can be found in the download area of our webpage.

→ [Download \(APK-file for Android\)](#)

Dismounting Advices

Remove the lower section of the sensor carefully and pulling straight out. **Pay close attention to the correct dismantling of the component!**

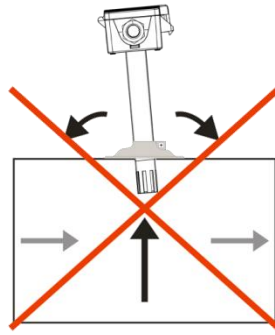

Dimensions (mm)

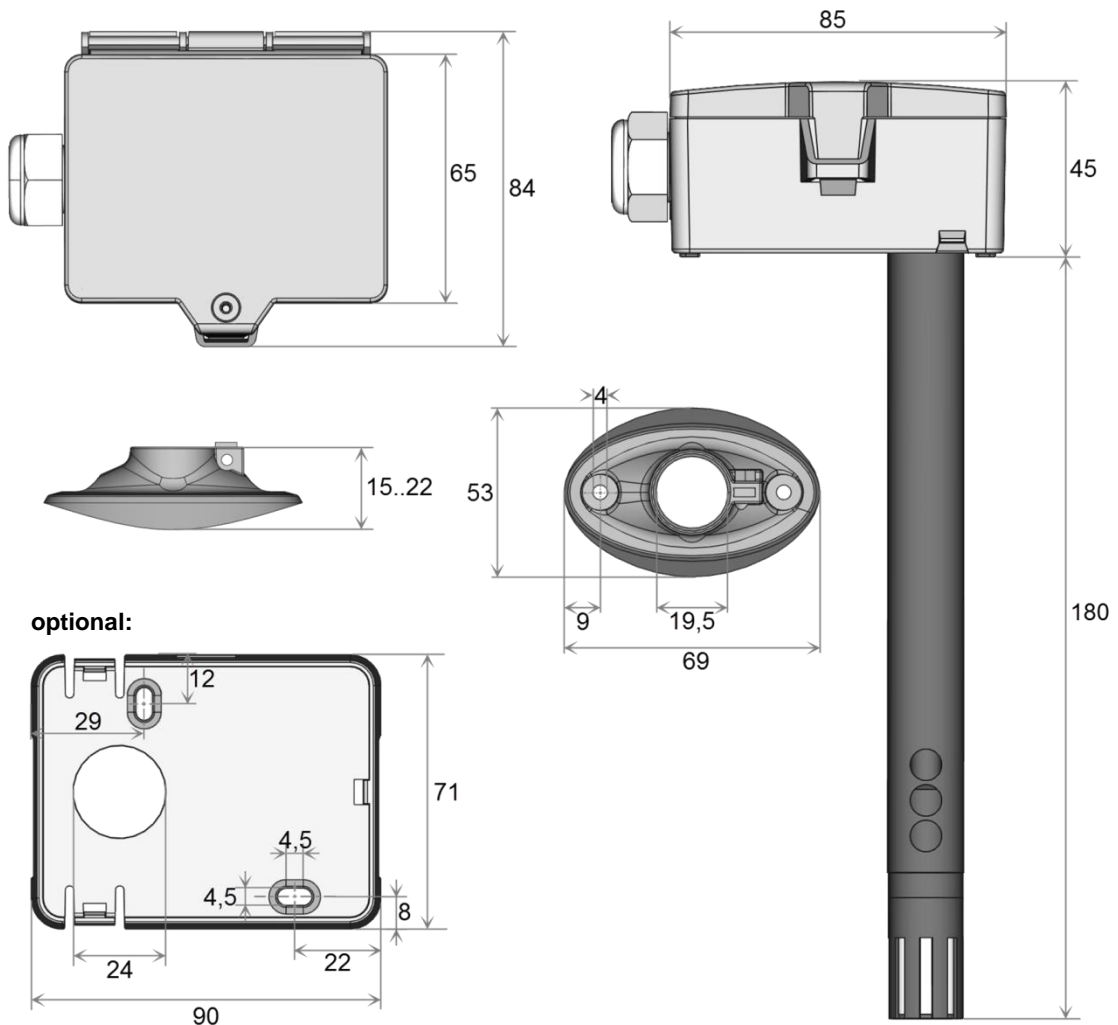

Accessories (included in delivery)

Mounting flange MF20 TPO
 Mounting kit 4
 • Cable entry M25 • Wago twofold terminal • Cover screw • 2 Screws (countersunk head)

Item No. 612562
 Item No. 674140

Accessories (optional)

Mounting base
 Filter stainless steel, wire mesh

Item No. 631228
 Item No. 231169