

Datasheet

Subject to technical alteration
Issue date: 31.03.2015



Application

Duct air quality sensor for combined detection of CO₂, relative humidity and temperature. Designed for control and monitoring applications.

Security Advice – Caution



The installation and assembly of the device must be performed by a skilled person.

The device should only be used for the appropriate application. Unauthorised conversions or alteration are prohibited! The modules must not be used in relation with equipment that threatens, directly or indirectly, human health or life or with applications that can result in danger for people, animals or assets.

For devices with controlling units (signal transducers, transmitters, etc.), it is important to make sure that the signal receiving device (actuators, generators, etc.) does not accept damaging or threatening conditions, that may arise from false signals during installation / configuration of the control unit. If necessary, disconnect the signal receiver from any source of power.

Please verify and consult:

- Laws, standards and regulations.
- The current condition of the device at the time of installation, to ensure safe installation.
- The devices technical data and installation manual.



Notes on Disposal

The product is considered electrical and electronic waste and must be disposed accordingly. Special treatment for specific components may be legally binding or ecologically sensible. The local and current applicable legislation must be followed.

Build-up of Self-Heating by Electrical Dissipative Power

Temperature sensors with electronic components always have a dissipative power, which affects the temperature measurement of the ambient air. The dissipation in active temperature sensors shows a linear increase with rising operating voltage. This dissipative power has to be considered when measuring temperature. In case of a fixed operating voltage ($\pm 0,2$ V) this is normally done by adding or reducing a constant offset value. As Thermokon transducers work with a variable operating voltage, only one operating voltage can be taken into consideration, for reasons of production engineering. Transducers 0..10 V / 4..20 mA have a standard setting at an operating voltage of 24 V =. That means, that at this voltage, the expected measuring error of the output signal will be the least. For other operating voltages, the offset error will be increased or lowered by a changing power loss of the sensor electronics. If a re-calibration should become necessary later directly on the sensor, this can be done by means of a trimming potentiometer on the sensor board.

Remark: Occurring draft leads to a better carrying-off of dissipative power at the sensor. Thus temporally limited fluctuations might occur upon temperature measurement.

Application Notice for Humidity Sensors

Refrain from touching the sensitive humidity sensor. Any touch of it will result in an expiration of warranty.

Under normal environmental conditions we recommend a recalibration interval of about 1 year to maintain the indicated accuracy. At high ambient temperatures and high humidity or when using the sensor in aggressive gases, an earlier recalibration or a change of the humidity sensor can become necessary. Such recalibrations or a probable sensor change are not part of the general warranty.

Application Notice for Air Quality Sensors CO₂

Refrain from touching the sensitive sensor. Any touch of it will result in an expiration of warranty.

Information about Indoor Air Quality CO₂

EN 13779 defines several classes for indoor air quality:

Category	CO ₂ content above the content in outdoor air in ppm		Description
	Typical range	Standard value	
IDA1	<400 ppm	350 ppm	High indoor air quality
IDA2	400.. 600 ppm	500 ppm	Mean indoor air quality
IDA3	600..1.000 ppm	800 ppm	Moderate indoor air quality
IDA4	>1.000 ppm	1.200 ppm	Low indoor air quality

Information about Self-Calibration Feature CO₂

All gas sensors are subject to drift caused by components. This fact results generally in the need to recalibrate the sensors regularly.

With Dual-Channel technique Thermokon integrates automatic self-calibration in the sensors for different fields of operation.

Therefore manual calibration is not necessary.

Technical Data

Output BUS	LON
Measuring values	CO ₂ + temperature + humidity
Power supply	15..24 V = (±10%) / 24 V~ (±10%)
Power consumption	max. 3 W (24 V =) 6 VA (24 V ~)
Measuring range CO ₂	0..2000 ppm
Measuring range temperature	0..+50 °C
Measuring range humidity	0..100% rH
Accuracy CO ₂	±75 ppm o. ±10% of measuring range (typ. at 21 °C)
Accuracy temperature	±1% of measuring range (typ. at 21 °C)
Accuracy humidity	±2% between 10..90% rH (typ. at 21 °C)
Repeatability CO ₂	<1% of full scale
Stability CO ₂	<2% full Scale over life of sensor
Temperature dependence	<0,2% of full scale per °C
Warm up time	<2 minutes
Response time	<10 minutes
Calibration	Self calibration dual channel
Sensor	NDIR (non dispersive infrared)
Ambient temperature	0..+50 °C
Ambient humidity	max. 85% rH none condensed
Protection	IP20 according to EN 60529
Terminal block	Terminal block, max. 1,5 mm ²
Enclosure colour	pure white
Enclosure material	PA6
Pipe material	PA6
Pipe colour	black
Pipe length	180 mm
Pipe diameter	19 mm
Filter material	Stainless steel, wire mesh
Notes	Incl. PE wire (L=1,5 m) and MF19 mounting flange
Interface	LON FTT
Weight:	approx. 450 g

Mounting advices

The devices are supplied in a ready to use condition and are already equipped with a 1,5 m connection cable. Thus, there is no need to open the device. If an opening of the cover becomes necessary, however, please make sure that the housing will be hermetically-sealed, again.

The installation in a ventilation duct is made by means of the mounting flange included (fixing screws are not included).

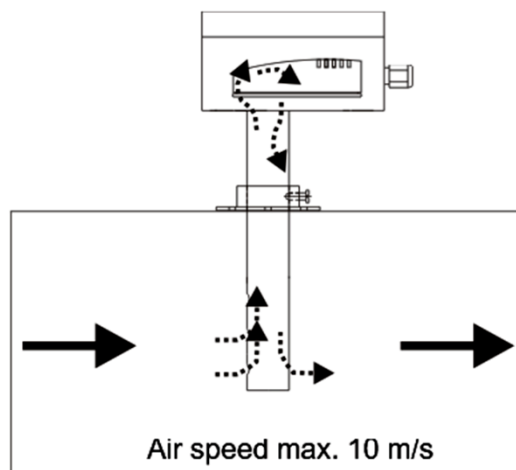

Terminal Connection Plan

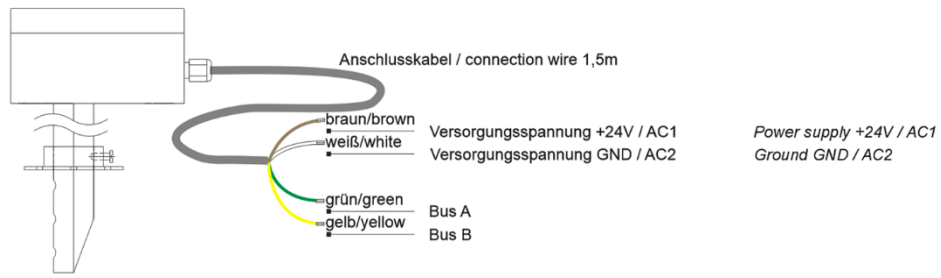

Dimensions (mm)

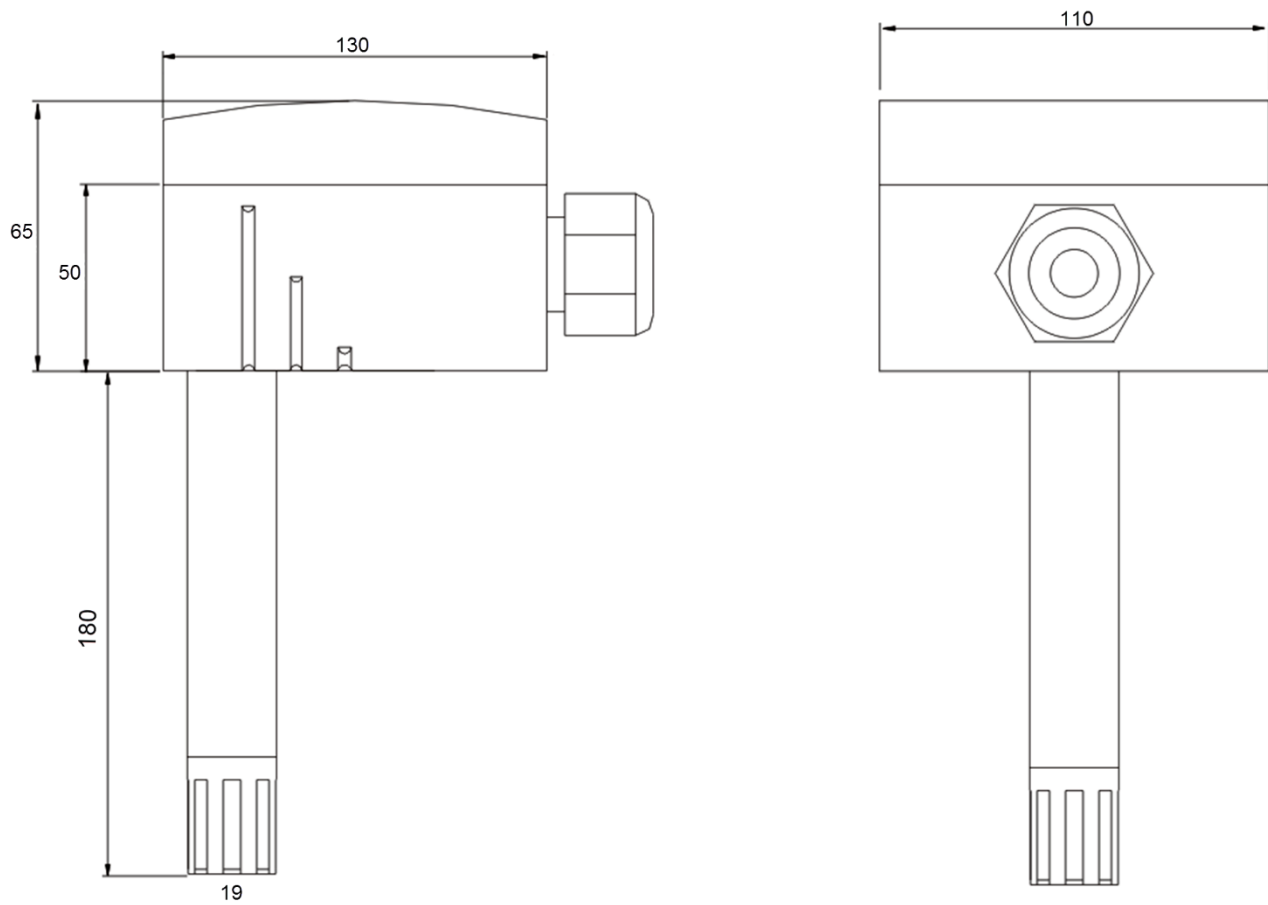

Optional Accessories

(D+S) 1 Set (each 2 pieces) rawl plugs and screws