

LK-SX CO2

Sensor for detection of carbon dioxide (CO₂) in air ducts

thermokon
Sensortechnik GmbH

Datasheet

Subject to technical alteration
Issue date: 23.04.2015



Application

Duct air quality sensor with hinged lid enclosure for detection of CO₂, optional with temperature and humidity. 0..10 V outputs. Designed for duct mounted applications.

Security Advice – Caution



The installation and assembly of electrical equipment must be performed by a skilled electrician.

The device should only be used for the appropriate application. Unauthorised conversions or alteration are prohibited! The modules must not be used in relation with equipment that threatens, directly or indirectly, human health or life or with applications that can result in danger for people, animals or assets. Before connecting devices, the installation must be isolated from the power source!

For devices with controlling units (signal transducers, transmitters, etc.), it is important to make sure that the signal receiving device (actuators, generators, etc.) does not accept damaging or threatening conditions, that may arise from false signals during installation / configuration of the control unit. If necessary, disconnect the signal receiver from any source of power.

The following procedure must be carried out:

1. Disconnect the device from power.
2. Ensure the device is secured against reconnection.
3. Verify the device is not powered.
4. Prior to reconnection, ensure that the enclosure is securely closed.

Please verify and consult:

- Laws, standards and regulations.
- The current condition of the device at the time of installation, to ensure safe installation.
- The devices technical data and installation manual.



Notes on Disposal

As a component of large-scale fixed installation, Thermokon products are intended to be used permanently as part of a building or a structure at a pre-defined and dedicated location. The Waste Electrical and Electronic Act (WEEE) is not applicable. However, the product may contain valuable materials that should not be recycled rather than disposed as domestic waste. Please note the relevant regulations for local disposal.

Information about Indoor Air Quality CO₂

EN 13779 defines several classes for indoor air quality:

Category	CO ₂ content above the content in outdoor air in ppm		Description
	Typical range	Standard value	
IDA1	<400 ppm	350 ppm	High indoor air quality
IDA2	400.. 600 ppm	500 ppm	Mean indoor air quality
IDA3	600.. 1.000 ppm	800 ppm	Moderate indoor air quality
IDA4	>1.000 ppm	1.200 ppm	Low indoor air quality

Information about Self-Calibration Feature CO₂

All gas sensors are subject to drift caused by components. This fact results generally in the need to recalibrate the sensors regularly.

With dual channel technology Thermokon integrates automatic self-calibration for different fields of operation. In contrast to common used ABC-Logic sensors with self-calibration dual channel are suitable for applications operating 24 hours, 7 days a week as for example hospitals.

Manual calibration is not necessary!

Technical Data

Output voltage	1x 0..10 V (V), load min. 10 kOhm
Measured values	CO ₂
Power supply	15..24 V = (±10%) or 24 V ~ (±10%)
Power consumption	max. 1,5 W (24 V =) 2,9 VA (24 V ~)
Measuring range CO ₂	0..2000 ppm
Accuracy CO ₂	±75 ppm o. ±10% of measuring range (typ. at 21 °C)
Drift CO ₂	<5% FS or <10% of measuring range per year ¹⁾
Calibration	Self calibration dual channel
Pressure dependence	typ. 0,135% of measured value per mm Hg
Temperature dependence	typ. 2 ppm per °C (0..+50 °C)
Sensor	NDIR (non dispersive, infrared)
Min. air speed	3 m/sec
Ambient temperature	0..+50 °C
Ambient humidity	max. 85% rH non condensed
Protection	IP65 according to EN 60529
Terminal block	Terminal block, max. 1,5 mm ²
Cable entry size	M20
Enclosure colour	pure white
Enclosure material	PA6
Pipe material	PA6
Pipe colour	black
Pipe length	180 mm
Pipe diameter	19 mm
Filter material	Stainless steel, wire mesh
Notes	MF19 flange included
Warm-up time	<2 minutes (operational), 15 minutes (max. accuracy)
Weight	approx. 350 g

¹⁾ Depending on the ambient atmosphere, the value may be higher.

Mounting advices

The sensor can be attached to a mounting flange (recommended) or directly to the ventilation duct.

When installing the device make sure, that the air inlets of the sensor tube are positioned in direction of flow!!!

In case of condensation in the air duct please install the device in a way, that possible condensate is able to run-off.

Mounting without mounting flange:

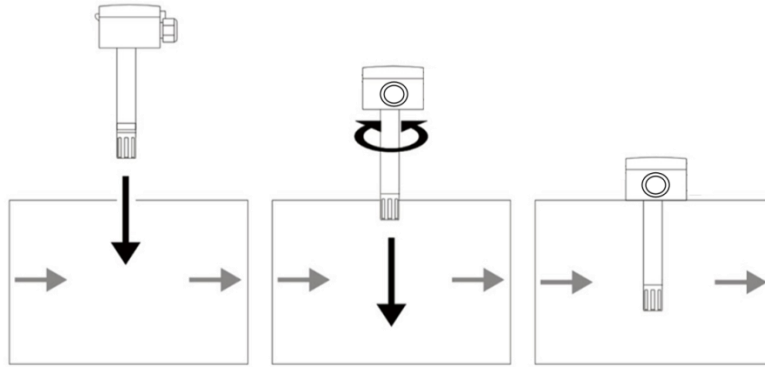

Maximum air velocity 10 m/s. Fix the sensor at the air duct.

Mounting with mounting flange:

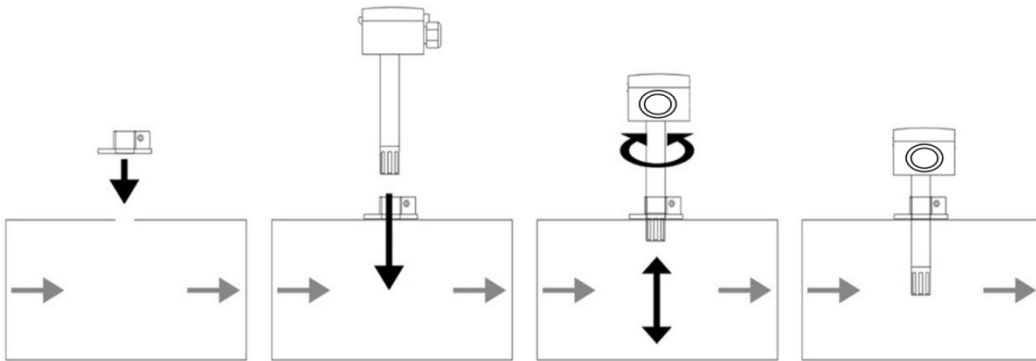

Maximum air speed 10 m/sec. Fix mounting flange at the air duct, fix the sensor at the mounting flange.

Dismounting advice

Unfix sensor and pull it out vertically. **Do not tilt the sensor during withdrawal!**

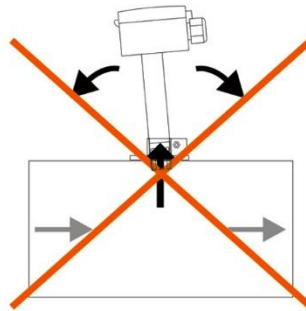

Terminal Connection Plan

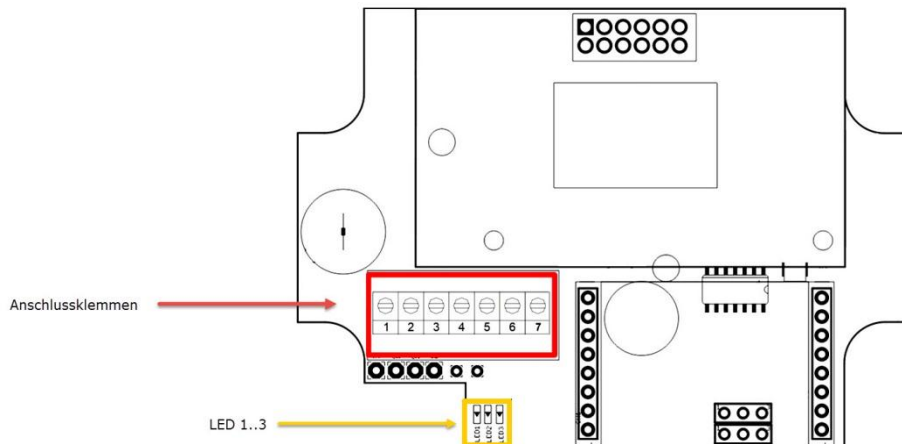

Connection clamps:

Clamp #	Function
1	24 V
2	GND
3	Not used
4	Not used
5	Not used
6	Output CO ₂ 0..10 V (without Offset)
7	Not used

Commissioning

Following a power reset, all LEDs are ON for 90 seconds. During this this warm-up time the output values are not valid.

The LEDs visualize the CO₂ concentration:

0..750 ppm	green LED ON
751..1250 ppm	yellow LED ON
1251..2000 ppm	red LED ON

Case of error

If an error occurs, the red LED flashes each second. The yellow and green LEDs encode the error type.

Green LED	Yellow LED	Error
flash	OFF	failure CO ₂ -Sensor

Application notice

During usage in air circulation dirt and dust may blind the sintered filter protecting the sensors. Then the sensor function may be handicapped.

When having dismantled the device, the functionality can be restored by air-cleaning with compressed air (filtered and free of oil), cleaned air or nitrogen. It is also possible to wash out the filter with distilled water. Severely polluted filters should be replaced.

Under normal conditions a one year interval for maintenance is recommend to keep the specified accuracy.

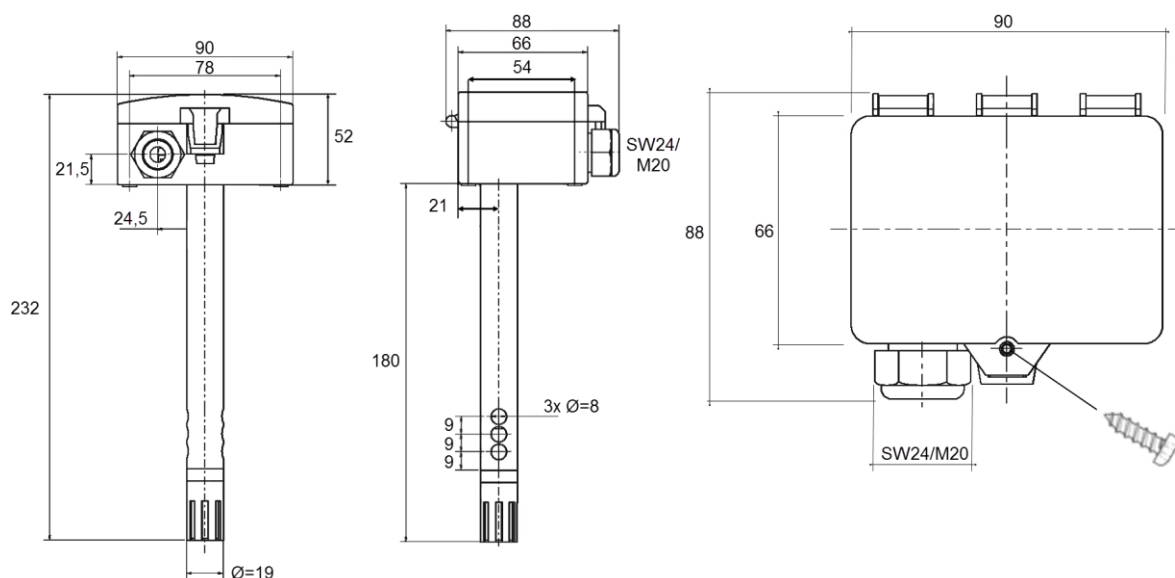
Dimension (mm)**Optional Accessories**

(MF19-PA) Mounting flange for mounting the sensor on the air duct.