

Datasheet

Subject to technical alteration
Issue date: 21.09.2018 • A003

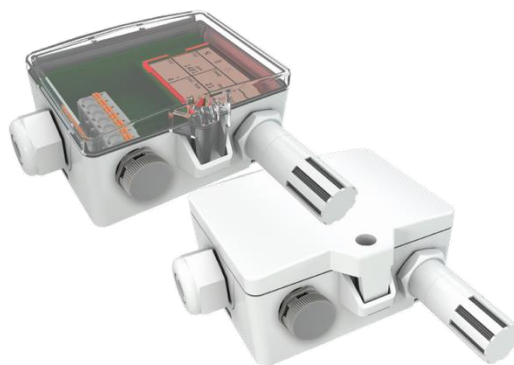

The following illustrations show the version with LCD

Application

Air quality sensor for measuring VOC air quality, CO₂, temperature and humidity in outdoor areas with 2 0..10 V output. LCD models with RGB background light have a transparent cover.

Types Available

Outdoor sensor CO₂ + VOC + temp + rH– active RS485 BACnet MS/TP | LCD

LA+ CO₂+VOC Temp_rH RS485 BACnet

LA+ CO₂+VOC LCD Temp_rH RS485 BACnet

Security Advice – Caution



The installation and assembly of electrical equipment should only be performed by authorized personnel.

The product should only be used for the intended application. Unauthorised modifications are prohibited! The product must not be used in relation with any equipment that in case of a failure may threaten, directly or indirectly, human health or life or result in danger to human beings, animals or assets. Ensure all power is disconnected before installing. Do not connect to live/operating equipment.

Please comply with

- Local laws, health & safety regulations, technical standards and regulations
- Condition of the device at the time of installation, to ensure safe installation
- This data sheet and installation manual

Notes on Disposal



As a component of a large-scale fixed installation, Thermokon products are intended to be used permanently as part of a building or a structure at a pre-defined and dedicated location, hence the Waste Electrical and Electronic Act (WEEE) is not applicable. However, most of the products may contain valuable materials that should be recycled and not disposed of as domestic waste. Please note the relevant regulations for local disposal.

General remarks concerning sensors

Especially with regard to passive sensors in 2-wire conductor versions, the wire resistance of the supply wire has to be considered. If necessary the wire resistance has to be compensated by the follow-up electronics. Due to self-heating, the wire current affects the measurement accuracy, so it should not exceed 1 mA.

When using lengthy connection wires (depending on the cross section used) the measuring result might be falsified due to a voltage drop at the common GND-wire (caused by the voltage current and the line resistance). In this case, 2 GND-wires must be wired to the sensor - one for supply voltage and one for the measuring current.

Sensing devices with a transducer should always be operated in the middle of the measuring range to avoid deviations at the measuring end points. The ambient temperature of the transducer electronics should be kept constant. The transducers must be operated at a constant supply voltage ($\pm 0,2$ V). When switching the supply voltage on/off, onsite power surges must be avoided.

Build-up of Self-Heating by Electrical Dissipative Power

Temperature sensors with electronic components always have a dissipative power, which affects the temperature measurement of the ambient air. The dissipation in active temperature sensors shows a linear increase with rising operating voltage. This dissipative power has to be considered when measuring temperature. In case of a fixed operating voltage ($\pm 0,2$ V) this is normally done by adding or reducing a constant offset value. As Thermokon transducers work with a variable operating voltage, only one operating voltage can be taken into consideration, for reasons of production engineering. Transducers 0..10 V / 4..20 mA have a standard setting at an operating voltage of 24 V =. That means, that at this voltage, the expected measuring error of the output signal will be the least. For other operating voltages, the offset error will be increased by a changing power loss of the sensor electronics. If a re-calibration should become necessary later directly on the sensor, this can be done via a corresponding software variable.

Remark: Occurring draft leads to a better carrying-off of dissipative power at the sensor. Thus temporally limited fluctuations might occur upon temperature measurement.

Application Notice for Humidity Sensors

Refrain from touching the sensitive humidity sensor/element. Touching the sensitive surface will void warranty.

For standard environmental conditions re-calibration is recommended once a year to maintain the specified accuracy.

When exposed to high ambient temperature and/or high levels of humidity or presence of aggressive gases (i.e. chlorine, ozone, ammonia) the sensor element may be affected and re-calibration may be required sooner than specified. Re-calibration and deterioration of the humidity sensor due to environmental conditions are not subject of the general warranty.

Information about Indoor Air Quality CO₂

EN 13779 defines several classes for indoor air quality:

Category	CO ₂ content above the content in outdoor air in ppm		Description
	Typical range	Standard value	
IDA1	<400 ppm	350 ppm	Good indoor air quality
IDA2	400.. 600 ppm	500 ppm	Standard indoor air quality
IDA3	600..1.000 ppm	800 ppm	Moderate indoor air quality
IDA4	>1.000 ppm	1.200 ppm	Poor indoor air quality

Information about Self-Calibration Feature CO₂

All gas sensors are subject to drift caused by components. This fact results generally in the need to recalibrate the sensors regularly.

With dual channel technology Thermokon integrates automatic self-calibration for different fields of operation. In contrast to common used ABC-Logic sensors with self-calibration dual channel are suitable for applications operating 24 hours, 7 days a week as for example hospitals.

Manual calibration is not necessary!

Application Notice for Air Quality Sensors VOC

Unlike CO₂ sensors, which specifically measure CO₂, mixed gas sensors detect a wide range of gases. The sensor signal does not indicate the type of gas or its concentration in ppm. Mixed gas sensors detect gases and vapours consisting of carbohydrates, or more generally gases that can be oxidised (burnt): Odours, perfume, cleaning fluid scent, tobacco smoke, new materials fumigations (furniture, carpets, paint, glue ...).

Unlike CO₂, which humans cannot sense, the amount of odours (VOC) indicates the level of air quality. VOC sensors have proven their value in a multitude of applications for many years.

Measuring principle:

Similar to a catalyst converter the organic molecules are burnt (oxidized) when in contact with the sensor's heated -dioxide surface, adding a small amount of heat combustion. The increased temperature is measured providing a signal proportional to the number of molecules being burnt. CO₂ cannot be detected as it cannot be further oxidized.

Refrain from touching the sensor's element sensitive surface. Touching the sensitive surface element will void warranty.

Information about Calibration VOC

Similar to a catalyst converter the VOC sensor will deteriorate over time, which will affect the sensitivity. This VOC sensor automatically compensates the decrease in sensitivity by dynamic auto-calibration.

The reference level of air quality is derived from the ambient conditions over a 72h period. The lowest reading within this 72h time period will be used as reference level, representing the "clean and fresh air level".

Technical Data

Measuring values	CO ₂ , VOC, temperature and humidity	
Output voltage	2x 0..10 V or 0..5 V, min. load 10 kΩ (live-zero configuration via Thermokon USEapp)	
Network technology	RS485 BACnet MS/TP	
Power supply	15..35 V = or 19..29 V ~	
Power consumption	max. 2,3 W (24 V =) max. 4,3 VA (24 V ~)	
Measuring range temp.	0..+50 °C (default setting) , optionally configured via Thermokon USEapp	
Measuring range humidity	0..100% rH non-condensing, optionally (enthalpy, absolute humidity, dew point)	
Measuring range CO₂	0..2000 ppm (default), 0..5000 ppm (optionally configured via Thermokon USEapp)	
Accuracy temperature	±0,5 K (typ. at 21 °C)	
Accuracy humidity	±2% between 10..90% rH (typ. at 21 °C)	
Accuracy CO₂	±50 ppm +3% of reading (typ. at 21 °C, 50% rH)	
Calibration	self-calibration, Dual Channel	
Sensor	NDIR (non-dispersiv, infrared)	
Display (optional)	LCD LCD 29x35 mm with RGB backlight	
Enclosure (type-dependent)	enclosure USE-M, PC, pure white, with removable cable entry	LCD cover PC, transparent
Protection	IP65 according to EN 60529	
Cable entry	M25, for wire max. Ø=7 mm, seal insert for fourfold cable entry	
Connection electrical	Mainboard removable plug-in terminal, max. 2,5 mm ²	Plug-in card removable plug-in terminal, max. 1,5 mm ²
Pipe	PC, pure white	
Filter	stainless steel wire mesh	
Ambient condition	0..+50 °C, max. 85% rH short term condensation	
Notes	mixed gas sensors detect gases and vapours which can be oxidised (burnt): Body odours, tobacco smoke, exhalations emitted by materials (furniture, carpets, paint, glue ...)	



Declaration of conformity

The declaration of conformity of the products can be found on our website <https://www.thermokon.de/>.

Mounting Advices

In case of outdoor installation avoid direct rain and sun contact. Probably use sun respectively rain protection. Cable entry from bottom or side. For side cable routing set loop so that precipitation can drain defined. Observe permissible ambient condition.

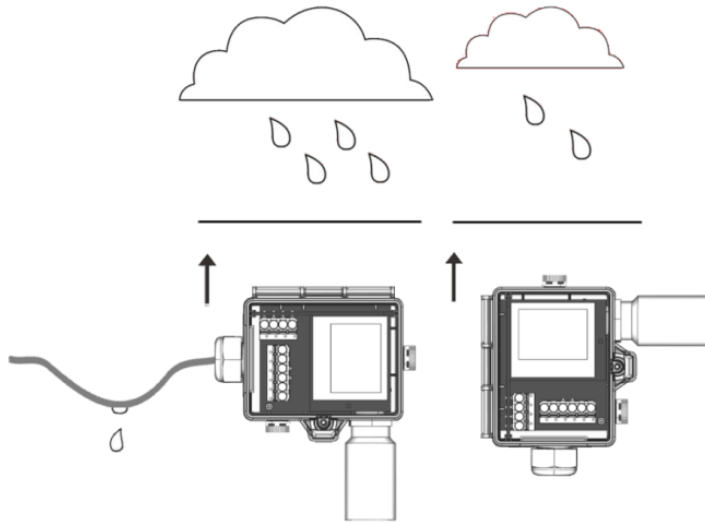

Configuration



The Thermokon bluetooth dongle with micro-USB is required for communication between USEapp and USE-M / USE L (Item No.: 668262). Commercial bluetooth dongles are not compatible.



Application-specific reconfiguration of the devices can be carried out using the Thermokon USEapp. The configuration is carried out in the voltage-supplied state.



The configuration-app and the app description can be found in the Google Play Store or in the Apple App Store.

Application notice



The housing cover must be completely closed in order to ensure the accuracy and reproducibility of the measured values during a test or service log via USEapp.

The Bluetooth dongle snaps into the socket easily. When removing, please fix the plug-in card (option PCB) so that it is not unintentionally pulled out.

Connection Plan

To change the output voltage range (default: 0..10 V to 0.5 V) via jumper, the display must be removed from the board first.

LA+ CO2+VOC Temp_rH LCD RS485 BACnet

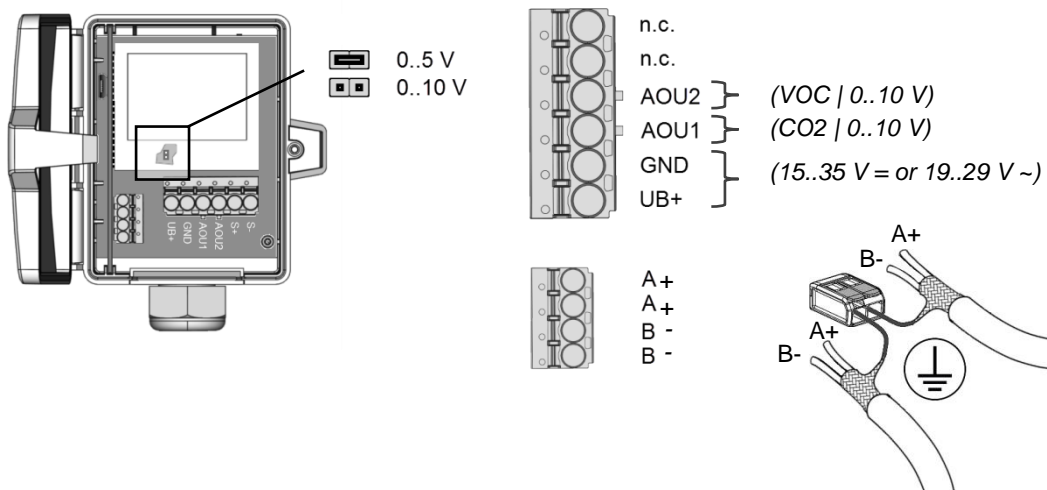

The BACnet address of the device is set binary coded in the range of 1 ... 127 via 7 dip-switches. (the address 0 is reserved and cannot be selected).



BACnet Objects:
USE-RS485 BACnet interface

A detailed description of the BACnet interface can be found in our downloadcenter:
→ [Download](#)

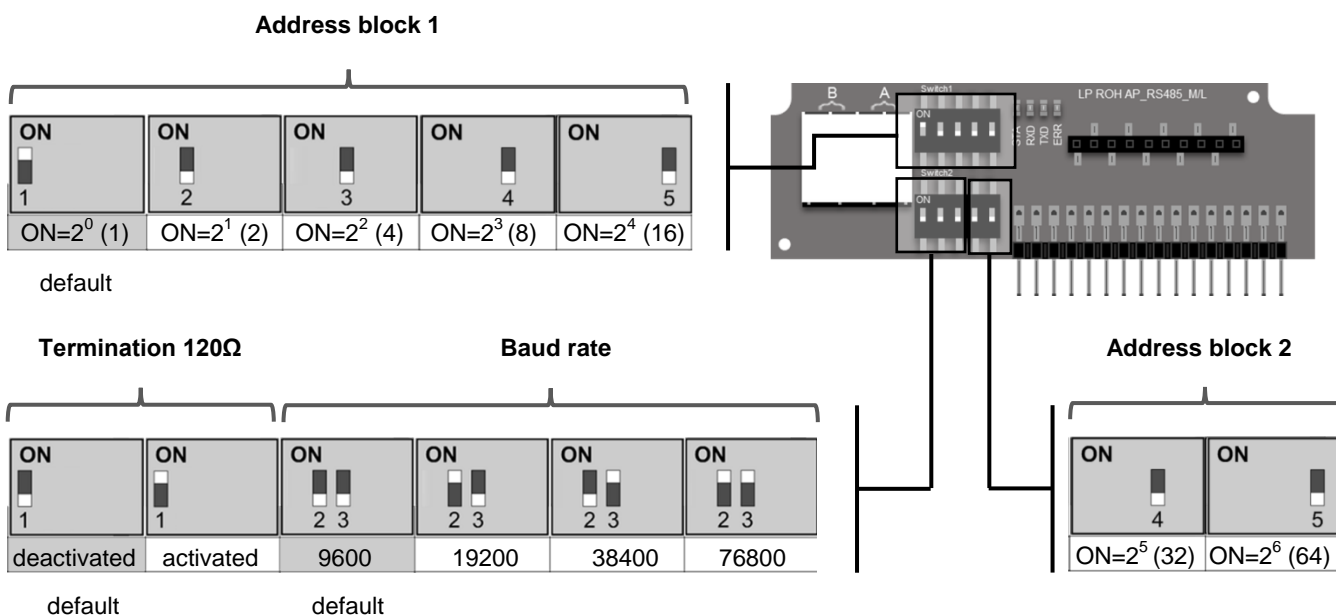

Measuring values

Object	Access	Description	Unit
AI-1	R	relative humidity	%rF
AI-5	R	CO2	ppm
AI-6	R	VOC	%
AI-7	R	CO2 VOC Mix	%

Object AV-38 = 1 (Unit SI)

Objects	Access	Description	Unit
AI-0	R	temperature	SI °C
AI-2	R	absolute humidity	SI g/m ³
AI-3	R	enthalpy	SI KJ/kg
Ai-4	R	dew point	SI °C

Object AV-38 = 2 (Unit Imperial)

Objects	Access	Description	Unit
AI-0	R	temperature	Imperial °F
AI-2	R	absolute humidity	Imperial gr/ft ³
AI-3	R	enthalpy	Imperial BTU/lb
Ai-4	R	dew point	Imperial °F

Dimensions (mm)

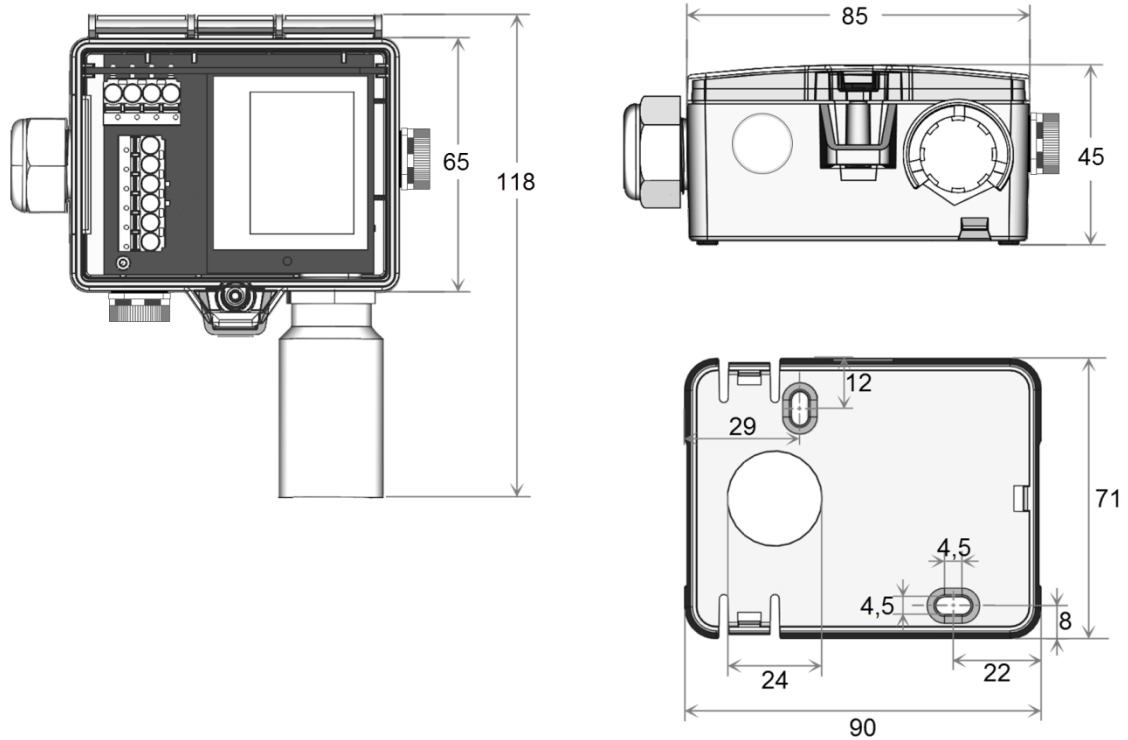

Accessories (included in delivery)

Mounting base

Item No. 631228

Mounting kit universal

Item No. 698511

• Cover screw + screw cover • 2 Rawplugs • 2 Screws (countersunk head) • 2 Screws (rounded head)

Accessories (optional)

Bluetooth dongle

Item No. 668262

Filter stainless steel, wire mesh

Item No. 231169