

FTA54+ RS485 Modbus

Outdoor sensor for relative humidity and temperature

thermokon[®]
HOME OF SENSOR TECHNOLOGY

Datasheet

Subject to technical alteration
Issue date: 26.06.2017



Application

Sensor for measuring humidity and temperature in outdoor areas. In delivery condition, the sensor is designed for measuring temperature and relative humidity. Alternatively the output can be set to absolute humidity, enthalpy or dew point (changeable via Thermokon USEapp). A mounting base for mounting on a level surface and fixing material are included in delivery.

Types Available

Outdoor sensor temperature + humidity – BUS

FTA54+ RS485 Modbus

Security Advice – Caution



The installation and assembly of electrical equipment should only be performed by authorized personnel.

The product should only be used for the intended application. Unauthorised modifications are prohibited! The product must not be used in relation with any equipment that in case of a failure may threaten, directly or indirectly, human health or life or result in danger to human beings, animals or assets. Ensure all power is disconnected before installing. Do not connect to live/operating equipment.

Please comply with

- Local laws, health & safety regulations, technical standards and regulations
- Condition of the device at the time of installation, to ensure safe installation
- This data sheet and installation manual

Notes on Disposal



As a component of a large-scale fixed installation, Thermokon products are intended to be used permanently as part of a building or a structure at a pre-defined and dedicated location, hence the Waste Electrical and Electronic Act (WEEE) is not applicable. However, most of the products may contain valuable materials that should be recycled and not disposed of as domestic waste. Please note the relevant regulations for local disposal.

Build-up of Self-Heating by Electrical Dissipative Power

Temperature sensors with electronic components always have a dissipative power, which affects the temperature measurement of the ambient air. The dissipation in active temperature sensors shows a linear increase with rising operating voltage. This dissipative power has to be considered when measuring temperature. In case of a fixed operating voltage ($\pm 0,2$ V) this is normally done by adding or reducing a constant offset value. As Thermokon transducers work with a variable operating voltage, only one operating voltage can be taken into consideration, for reasons of production engineering. Transducers 0..10 V / 4..20 mA have a standard setting at an operating voltage of 24 V =. That means, that at this voltage, the expected measuring error of the output signal will be the least. For other operating voltages, the offset error will be increased by a changing power loss of the sensor electronics. If a re-calibration should become necessary later directly on the sensor, this can be done by means of a trimming potentiometer on the sensor board.

Remark: Occurring draft leads to a better carrying-off of dissipative power at the sensor. Thus temporally limited fluctuations might occur upon temperature measurement.

Application Notice for Humidity Sensors

Refrain from touching the sensitive humidity sensor/element. Touching the sensitive surface will void warranty.

For standard environmental conditions re-calibration is recommended once a year to maintain the specified accuracy.

When exposed to high ambient temperature and/or high levels of humidity or presence of aggressive gases (i.e. chlorine, ozone, ammonia) the sensor element may be affected and re-calibration may be required sooner than specified. Re-calibration and deterioration of the humidity sensor due to environmental conditions are not subject of the general warranty.

Technical Data

Measuring values	temperature, humidity (humidity output configurable)
Output voltage	2x 0..10 V or 0..5 V, min. load 10 k Ω (live-zero configuration via Thermokon USEapp)
Network technology	RS485 Modbus
Power supply	15..35 V = or 19..29 V ~
Power consumption	max. 0,4 W (24 V =) 0,8 VA (24 V ~)
Measuring range temp.	-20..+80 °C (default setting), optionally configured via Thermokon USEapp
Measuring range humidity	0..100% rH non-condensing, optionally configured via Thermokon USEapp (enthalpy, absolute humidity, dew point)
Accuracy temperature	$\pm 0,3$ K (typ. at 21 °C)
Accuracy humidity	$\pm 2\%$ between 10..90% rH (typ. at 21 °C)
Enclosure	enclosure USE-M, PC, pure white
Protection	IP65 according to EN 60529
Cable entry	M25 for cable max. $\varnothing=7$ mm, seal insert for fourfold cable entry
Connection electrical	removable plug-in terminal, max. 2,5 mm ²
Modbus clamp	removable plug-in terminal, max. 1,5 mm ²
Pipe	PC, pure white
Filter	stainless steel wire mesh
Ambient condition	-31..+70 °C, short term condensation

Mounting Advices

In case of outdoor installation avoid direct rain and sun contact. Probably use sun respectively rain protection. Cable entry from bottom or side. For side cable routing set loop so that precipitation can drain defined. Observe permissible ambient condition.

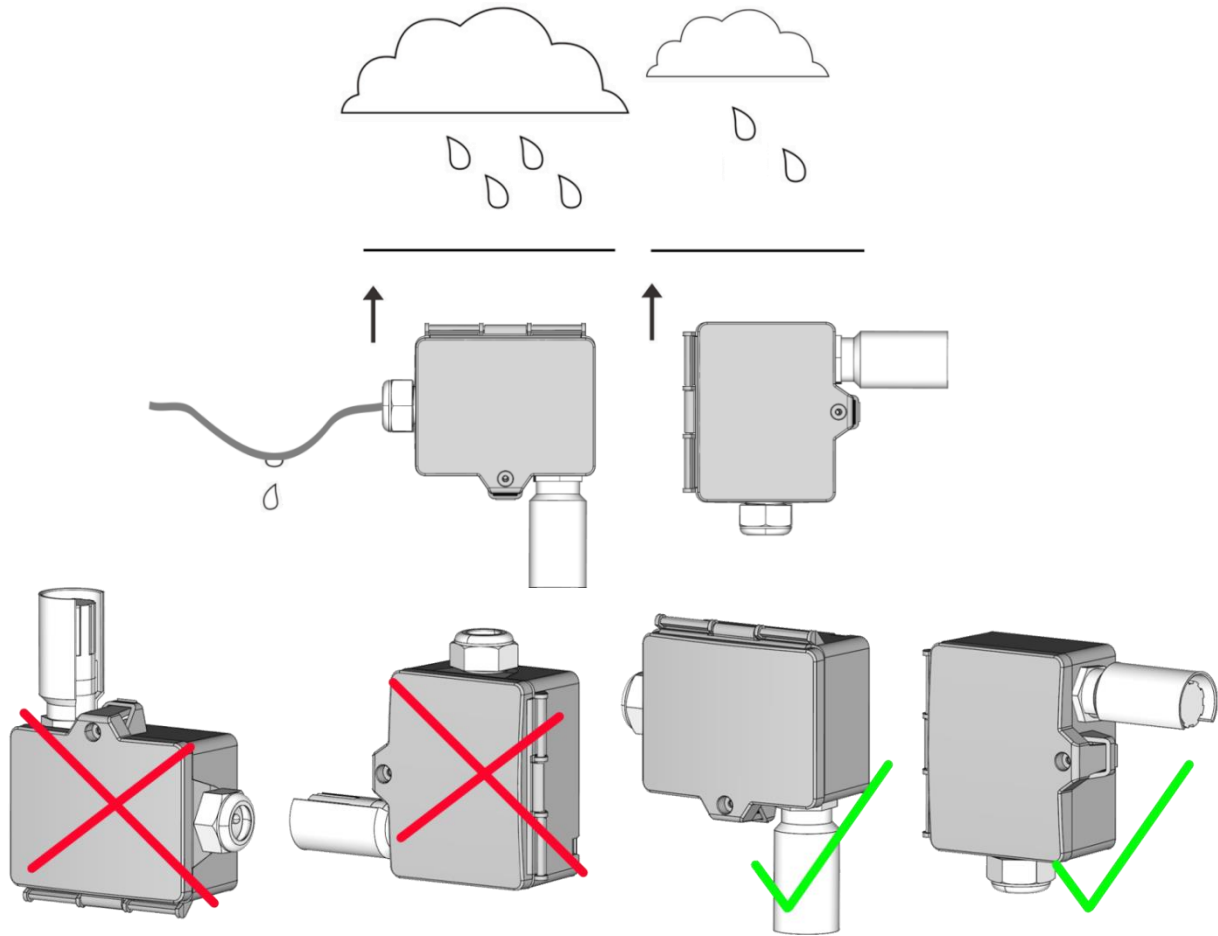

Connection Plan

If the RS485 cable is looped through, connect both cable shields using the enclosed 2-pol. Connect terminal as shown.

FTA54+ RS485 Modbus

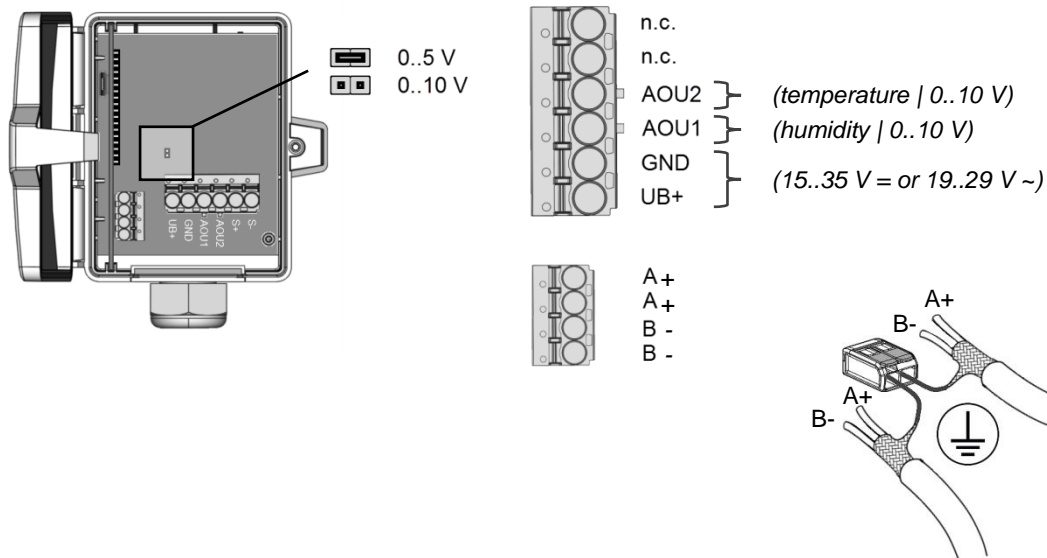

The modbus address of the device is set in the range of 1 ... 31 (binary encoded) using a 5-pole DIP switch. With address 0 via DIP, an extended address range (32..247) is available via USEapp.



Modbus addresses:

USE-RS485 Modbus Interface

A detailed description of the Modbus addresses can be found under the following link:

→ [Download](#)

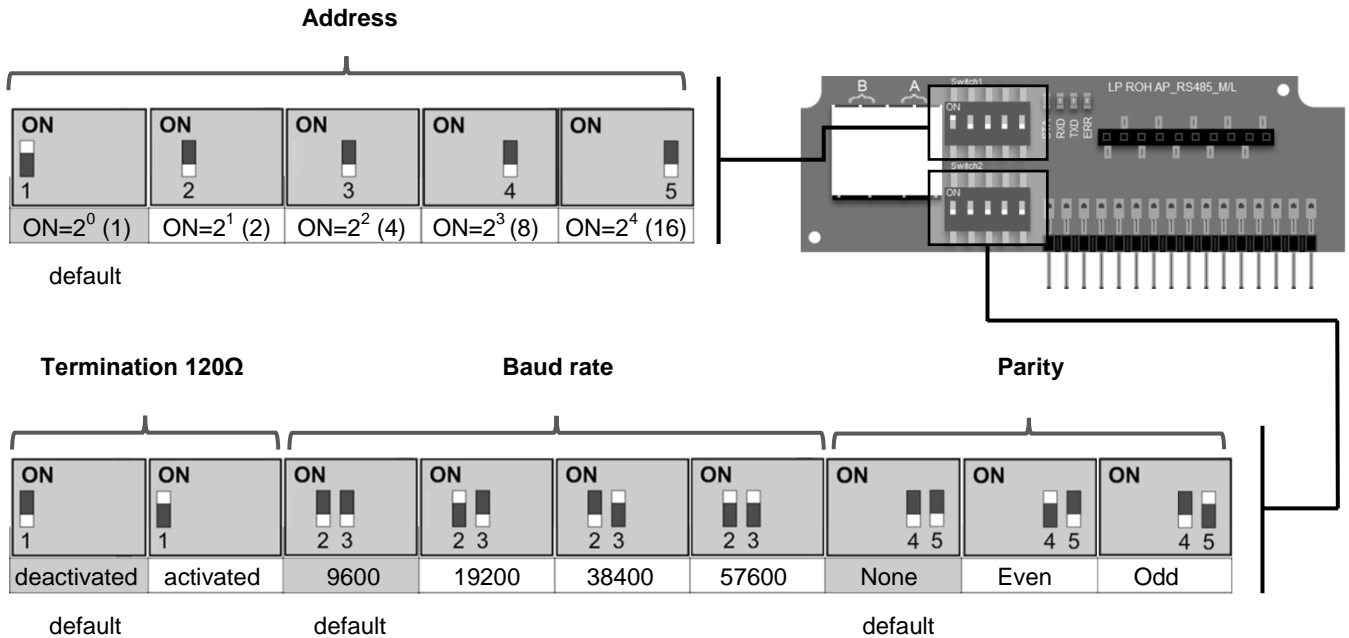

Configuration



The Thermokon bluetooth dongle with micro-USB is required for communication between USEapp and USE-M / USE L (Item No.: 668262). Commercial bluetooth dongles are not compatible.

Application-specific reconfiguration of the devices can be carried out using the Thermokon USEapp. The configuration is carried out in the voltage-supplied state.



The configuration-app and the app description can be found in the download area of our webpage.

→ [Download \(APK-file for Android\)](#)

Dimensions (mm)

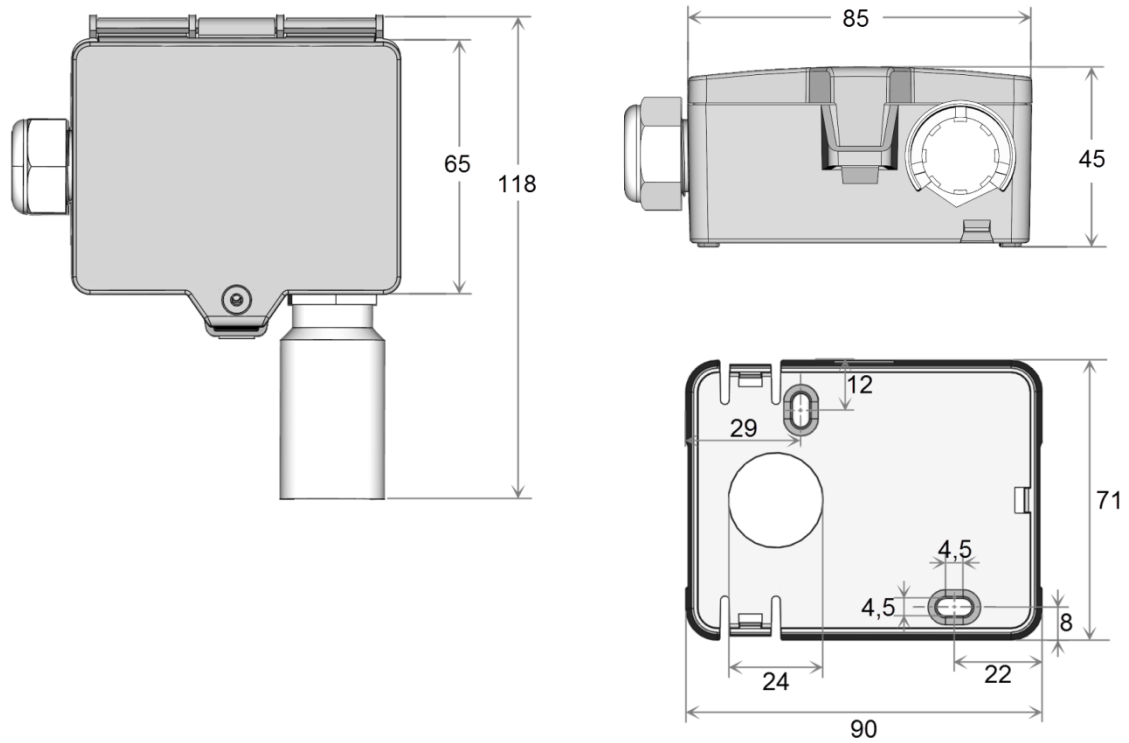

Accessories (included in delivery)

Rain protection
 Mounting base
 Mounting kit 7
 • Cable entry M25 • Wago twofold terminal • Cover screw • 2 Rawlplugs • 2 Screws (countersunk head)

Item No. 670715
 Item No. 631228
 Item No. 674140

Accessories (optional)

Filter stainless steel, wire mesh

Item No. 231169