

Data Sheet

Subject to technical alteration
Issue date: 07.07.2015



Application

The frost protection thermostat TFR is used for downstream temperature monitoring of water air heaters in ventilation and air-conditioning systems to prevent frost damages. It has a small differential gap and a good repeatability. The reset can be done automatically or manually in case of type -R.

The frost protection thermostat can be used to initiate the following frost protection functions:

- Stop fan
- Close outside air dampers
- Open heating coil valve 100%
- Star heating coil pump
- Switch-off chiller (condenser) and humidifier
- Trip visual and/or audible frost alarm

Types available

TFR xx	Frost protection thermostat, capillary tube length xx = 1,8 m / 3 m / 6 m / 12 m, automatic reset
TFR xx-R	Frost protection thermostat, capillary tube length xx = 1,8 m / 3 m / 6 m / 12 m, manual reset



Security Advice – Caution

The installation and assembly of electrical equipment should only be performed by authorized personnel.

The product should only be used for the intended application. Unauthorised modifications are prohibited! The product must not be used in relation with any equipment that in case of failure may threaten, directly or indirectly, human health or life or result in danger to human beings, animals or assets. Ensure all power is disconnected before installing. Do not connect to live/operating equipment.

CAUTION! Risk of electric shock due to live components within the enclosure, especially devices with mains voltage supply (usually between 90..265 V).

Please comply with

- Local laws, health & safety regulations, technical standards and regulations
- Condition of the device at the time of installation, to ensure safe installation
- This data sheet and installation manual



Notes on Disposal

As a component of a large-scale fixed installation, Thermokon products are intended to be used permanently as part of a building or a structure at a pre-defined and dedicated location, hence the Waste Electrical and Electronic Act (WEEE) is not applicable. However, most Thermokon products contain valuable materials that should be recycled rather than disposed as domestic waste. Please note the relevant regulations for local disposal.

Technical Data

Measuring values	temperature
Medium	air
Output switch contact	single pole change over, contact rating max. 10 A
Set point range	-10..+12 °C (factory setting +5 °C)
Switching values	Differential gap: 2 °C ±1 °C
Accuracy temperature	±0,5 °C
Enclosure	Base part PA6 GK30, light grey, cover ABS, transparent
Capillary pipe	Copper with tube filling R 507, 1,8 m, 3 m, 6 m, 12 m, Sensor operating length approx. 600 mm, contact material Ag/Ni (90%/10%), gold plated (3 µm)
Protection	IP65 according to EN 60529
Cable entry	M16
Connection electrical	Terminal block max. 2,5 mm ²
Ambient condition	-35..+70 °C, max. 85% rH, non-condensed
Shipment	Mounting Angle PA6 GF30 (6 pcs) Rubber grommets (2 pcs)

Mounting Advices

Withdrawable Tray

It is recommended to mount the frost protection thermostat on a special withdrawable tray directly downstream of the heating coil. The connecting cable must be long enough to enable the tray to be inserted and removed smoothly. For heating coils with a large cross section several frost protection thermostats can be fitted and connected in series. In such cases, the temperature set point is set individually for each frost protection thermostat.

Frost Protection Thermostat

The ambient temperature of frost protection thermostat housing (with the test loop) must be at least 2 °C above the pre-adjusted set point. If this cannot be guaranteed (e.g. outdoors or in exposed spaces), housing and test loop must be installed inside the supply air unit.

Capillary Tube

The capillary tube must be mounted on the downstream side of the heating coil (and on the upstream side in case of cooling coils). It should be looped diagonally across the heat exchanger pipes at a distance of approx. 5 cm and should cover the entire area evenly. For test purposes, it is recommended to have a loop of approx. 60 cm directly beneath the housing outside the entry to the duct. To prevent damage to the capillary tube a minimum bending radius of 20 mm must be ensured. Mounting can be facilitated by using the capillary mounting angle.

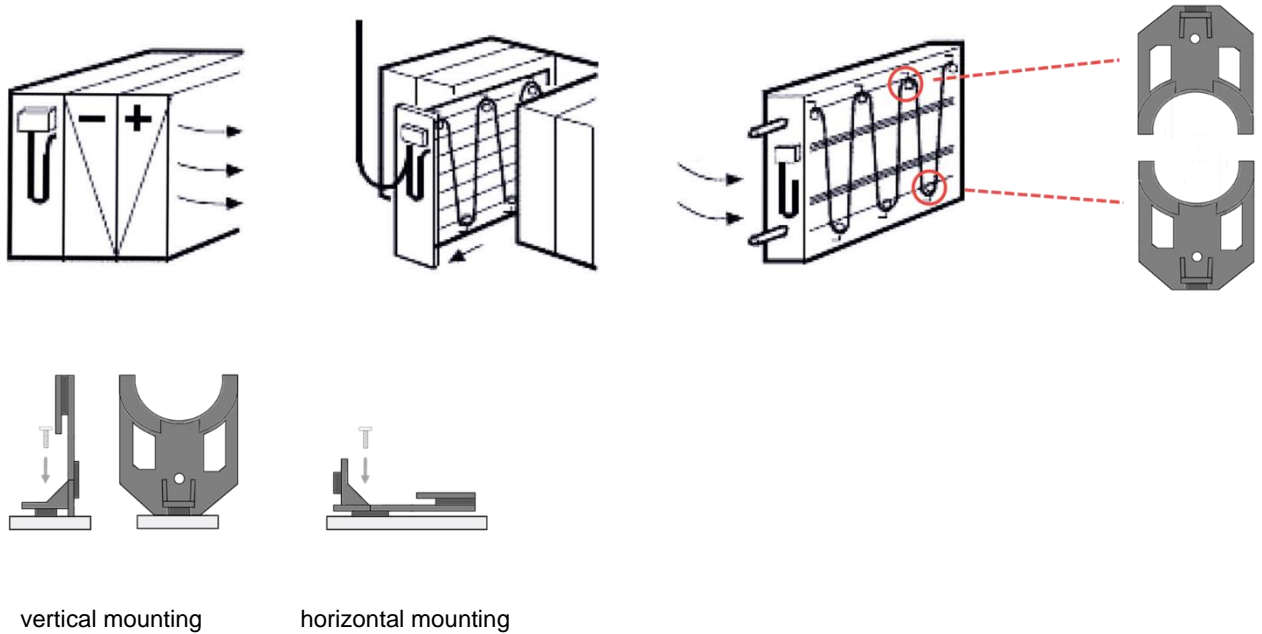

Function Description and Connection plan

The frost protection thermostat trips when the temperature drops below the selected set point over a capillary length of 60 cm (contact C-2 closes). Simultaneously contact C-3 breaks and can be used as a signal contact. An automatic reset is made when the temperature exceeds the adjusted set point again (contact C-3 closes). The TFR xx is “self-secured”, i.e. in case of a capillary tube diaphragm damage, it switches automatically to the heating function. Contact C-2 closes and can thus be used as an operating contact. The air temperature is measured over the full length of the capillary tube. The gas filled diaphragm system and the capillary tube are forming a unit of measurement which is mechanically linked to the micro-switch.

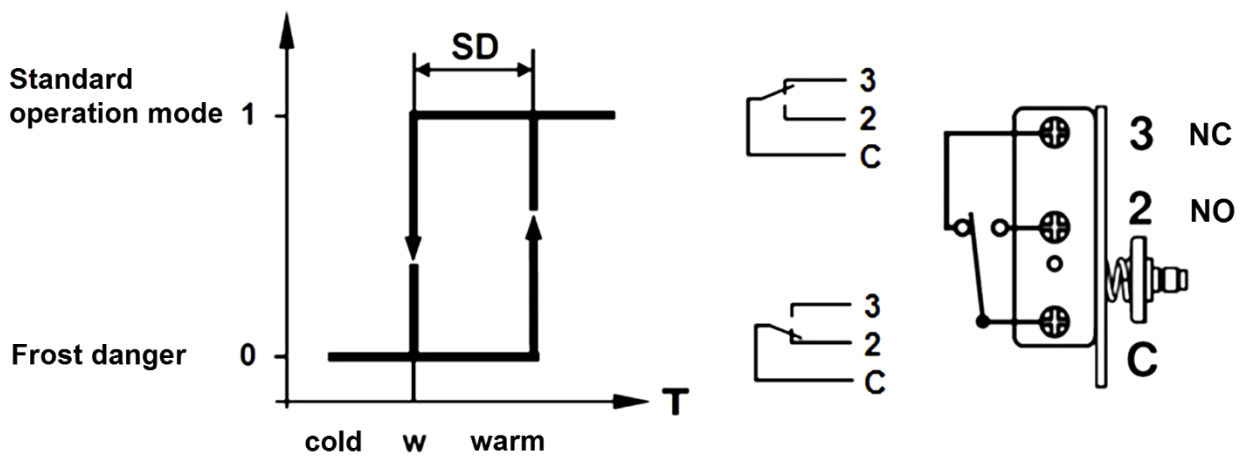

Commissioning

After removal of the screws of the transparent cover the set point can be adjusted with the dial indicator. To simulate frost conditions, the test loop can be immersed in a vessel of iced water.

Dimensions (mm)

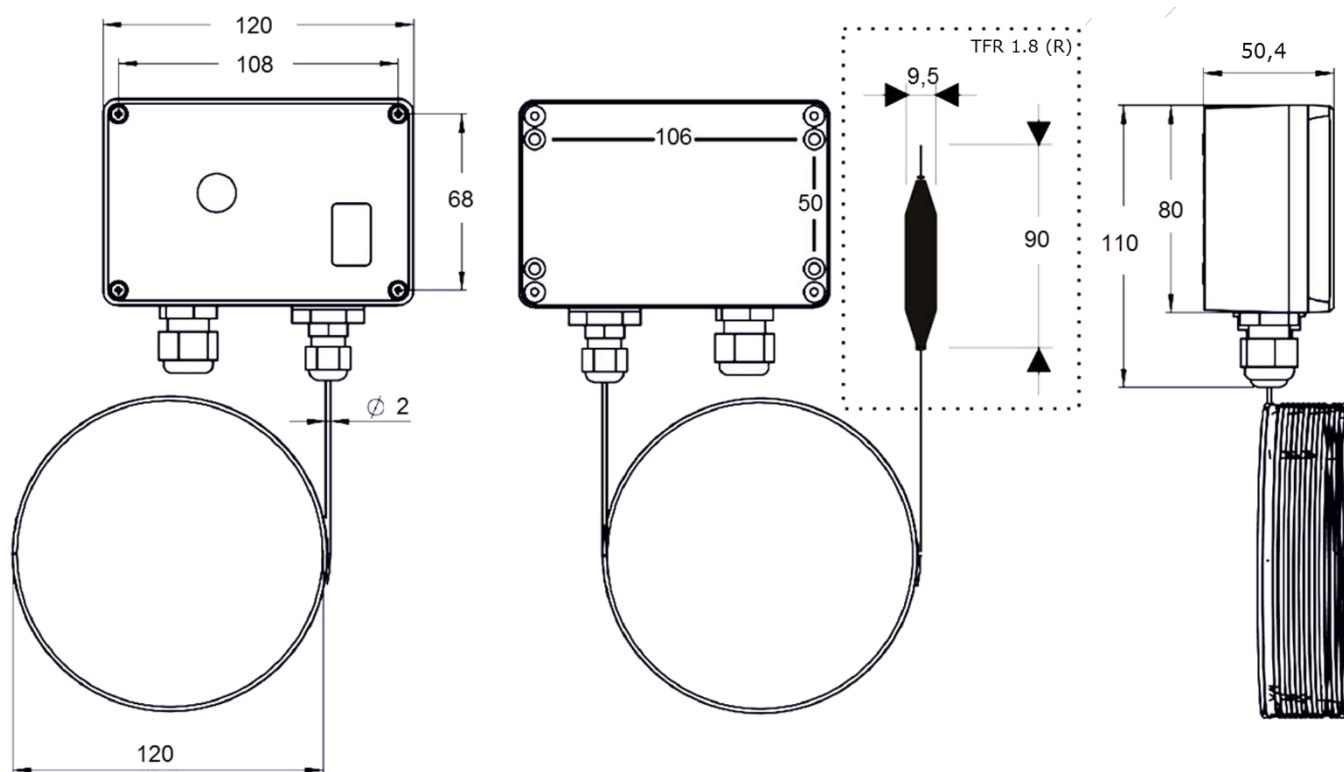

Accessories (optional)

Mounting flange MF2/TPO

Item No. 435642 (not compatible with TFR 1,8 and TFR 1,8-R)

Mounting Angle Set

Item No. 440394