

Datasheet

Subject to technical alteration
Issue date: 30.01.2017



Application

Immersion sensor with hinged lid enclosure USE complete and integrated thermowell pocket for temperature measurement of gases and liquids in pipework applications. Sensor is especially designed for fast processes. Ideal for e.g. hot tap water process when a very fast feedback is needed for a pleasant control result.

Types Available

Immersion sensor temperature – passive

SFK02+ <sensor> <xxx>.06/04

Immersion sensor temperature – active TRV 0..10 V | TRA 4..20 mA

SFK02+ TRV MultiRange <xxx>.06/04

SFK02+ TRA MultiRange <xxx>.06/04

<Sensor>: PT100/PT1000/Ni1000/Ni1000TK5000/NTC.../PTC...other sensors on request

<xxx>: mounting length 50/100/200/300 mm

MultiRange: Measuring ranges adjustable at the transducer

Security Advice – Caution



The installation and assembly of electrical equipment should only be performed by authorized personnel.

The product should only be used for the intended application. Unauthorised modifications are prohibited! The product must not be used in relation with any equipment that in case of a failure may threaten, directly or indirectly, human health or life or result in danger to human beings, animals or assets. Ensure all power is disconnected before installing. Do not connect to live/operating equipment.

Please comply with

- Local laws, health & safety regulations, technical standards and regulations
- Condition of the device at the time of installation, to ensure safe installation
- This data sheet and installation manual

Notes on Disposal



As a component of a large-scale fixed installation, Thermokon products are intended to be used permanently as part of a building or a structure at a pre-defined and dedicated location, hence the Waste Electrical and Electronic Act (WEEE) is not applicable. However, most of the products may contain valuable materials that should be recycled and not disposed of as domestic waste. Please note the relevant regulations for local disposal.

General remarks concerning sensors

Especially with regard to passive sensors in 2-wire conductor versions, the wire resistance of the supply wire has to be considered. If necessary the wire resistance has to be compensated by the follow-up electronics. Due to self-heating, the wire current affects the measurement accuracy, so it should not exceed 1 mA. When using lengthy connection wires (depending on the cross section used) the measuring result might be falsified due to a voltage drop at the common GND-wire (caused by the voltage current and the line resistance). In this case, 2 GND-wires must be wired to the sensor - one for supply voltage and one for the measuring current.

Sensing devices with a transducer should always be operated in the middle of the measuring range to avoid deviations at the measuring end points. The ambient temperature of the transducer electronics should be kept constant. The transducers must be operated at a constant supply voltage ($\pm 0,2$ V). When switching the supply voltage on/off, onsite power surges must be avoided.

Build-up of Self-Heating by Electrical Dissipative Power

Temperature sensors with electronic components always have a dissipative power, which affects the temperature measurement of the ambient air. The dissipation in active temperature sensors shows a linear increase with rising operating voltage. This dissipative power has to be considered when measuring temperature. In case of a fixed operating voltage ($\pm 0,2$ V) this is normally done by adding or reducing a constant offset value. As Thermokon transducers work with a variable operating voltage, only one operating voltage can be taken into consideration, for reasons of production engineering. Transducers 0..10 V / 4..20 mA have a standard setting at an operating voltage of 24 V =. That means, that at this voltage, the expected measuring error of the output signal will be the least. For other operating voltages, the offset error will be increased by a changing power loss of the sensor electronics. If a re-calibration should become necessary later directly on the sensor, this can be done by means of a trimming potentiometer on the sensor board.

Remark: Occurring draft leads to a better carrying-off of dissipative power at the sensor. Thus temporally limited fluctuations might occur upon temperature measurement.

Technical Data

Measuring values		temperature
Medium		gases, fluids
Output voltage	passive	depending on used sensor
	TRV	1x 0..10 V, min. load 5 k Ω
Output Amp	TRA	1x 4..20 mA, max. load 500 Ω
Power supply	TRV	15..24 V = ($\pm 10\%$) or 24 V ~ ($\pm 10\%$)
	TRA	15..24 V = ($\pm 10\%$)
Power consumption	TRV	typ. 0,4 W (24 V =) 0,8 VA (24 V ~)
	TRA	typ. 0,5 W (24 V =)
Measuring range temp	passive	-50..+125 +150 +160 +260 °C, depending on used sensor
	TRV TRA	adjustable at the transducer: -50..+50 -20..+80 -15..+35 -10..+120 0..+50 0..+100 0..+160 0..+250 °C, default setting: 0..+160 °C
Accuracy temperature	passiv	typ. $\pm 0,3$ K (typ. bei 21 °C), abhängig vom verwendeten Sensor $\pm 1\%$ of Measuring range (typ. at 21 °C) time constant: $T_{63\%}$ 2,5 s
Sensor	passive	2-wire (standard), 3-wire or 4-wire
Enclosure		enclosure USE-S, PC, pure white
Protection		IP65 according to EN 60529, SI-Protection
Cable entry		M16 for cable max. $\varnothing=8$ mm, removeable
Connection electrical		removeable plug-in terminal, max. 2,5 mm ²
Pocket		stainless steel V4A, $\varnothing=6$ 4 mm, mounting length: 50 100 200 300 mm, thread R 1/2"
Ambient condition	TRV TRA	-50..+160 °C (only end of sensor), optional -80..+260 °C (only end of sensor),
	passive	-35..+70 °C, max. 85% rH short term condensation -35..+90 °C, max. 85% rH short term condensation

Mounting Advices

For risk of condensate permeation in the sensor tube respectively in the immersion pocket the bushing must be installed in a position that occurred condensate can run off. Mounting with immersion pocket for usage in liquid media. Use contact fluid for better heat transfer between sensor and measuring medium.

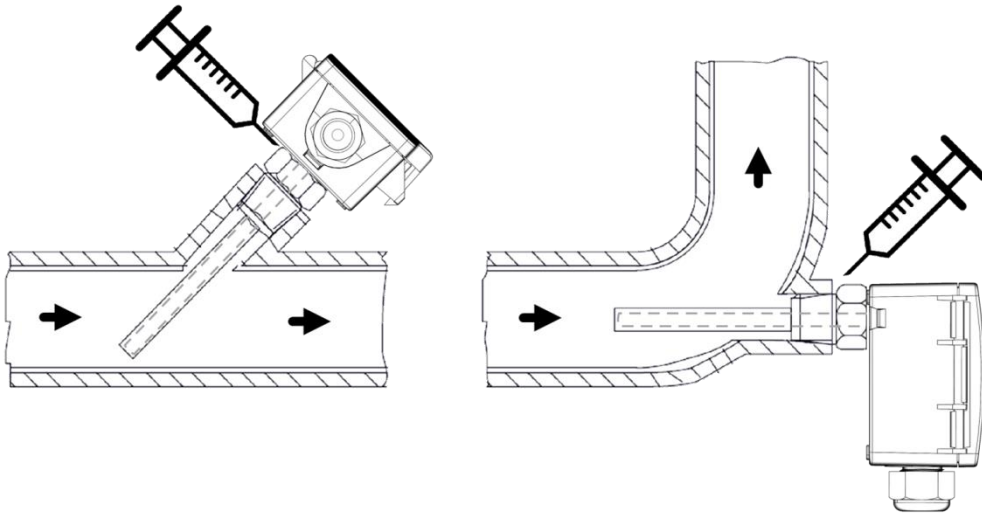

Connection Plan and Configuration

The adjustment of the measuring ranges is made by changing the jumpers in a de-energized state. The output value of the new measuring range is available after 2 seconds.

TRA:
4..20 mA

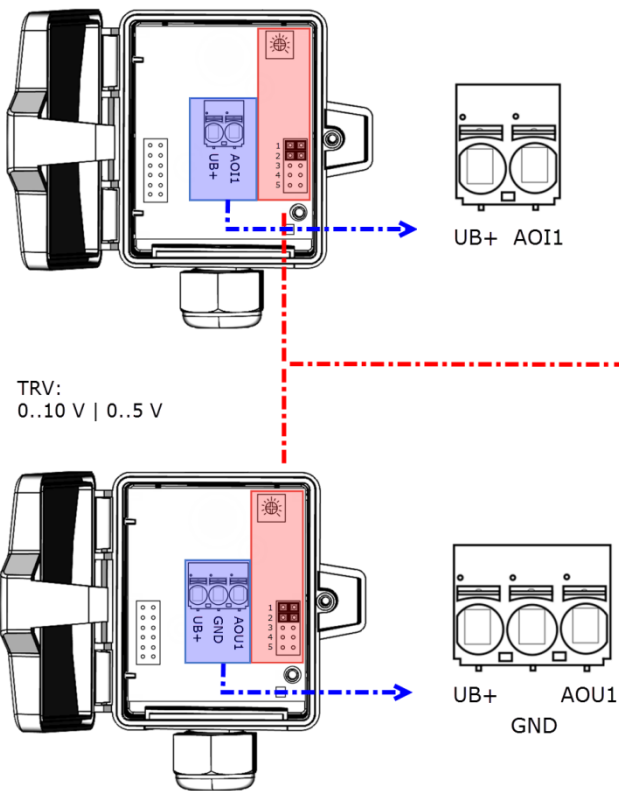

TRV:
0..10 V | 0..5 V

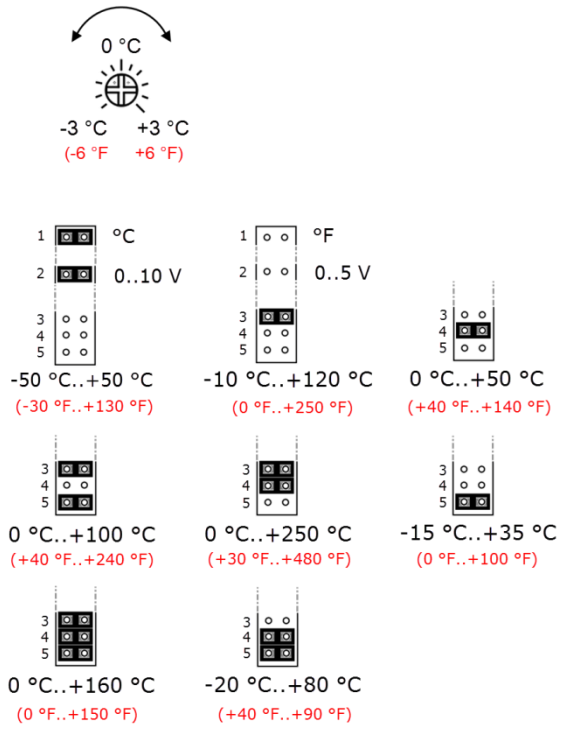

fig. (Measuring range and offset adjustment, default settings: 0 °C..+160 °C | 0 K)

Passiv

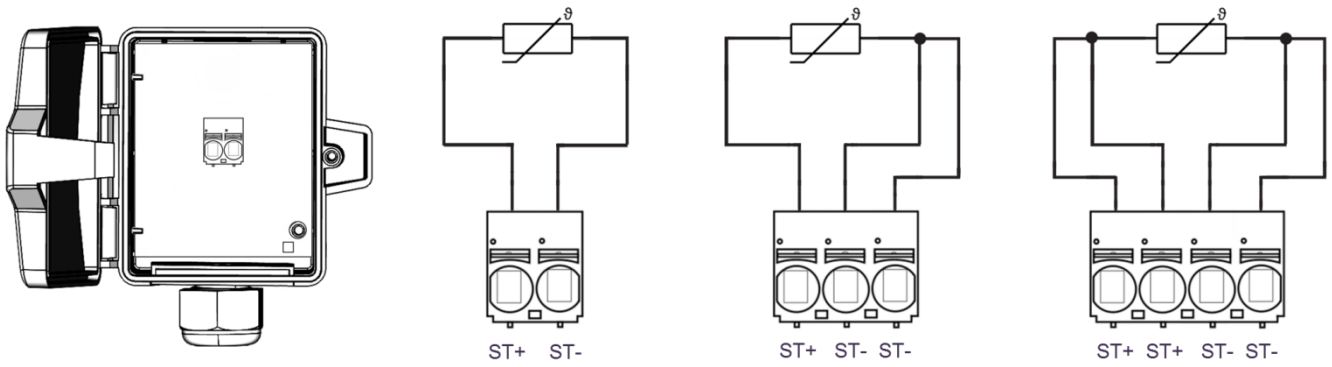
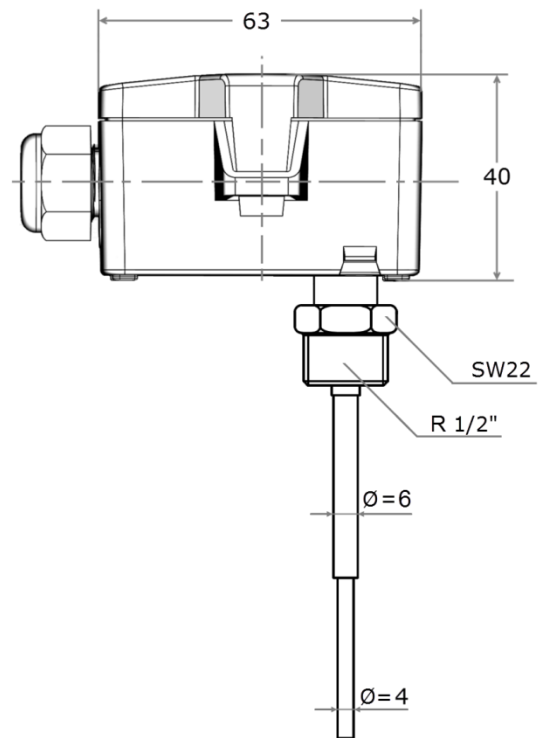
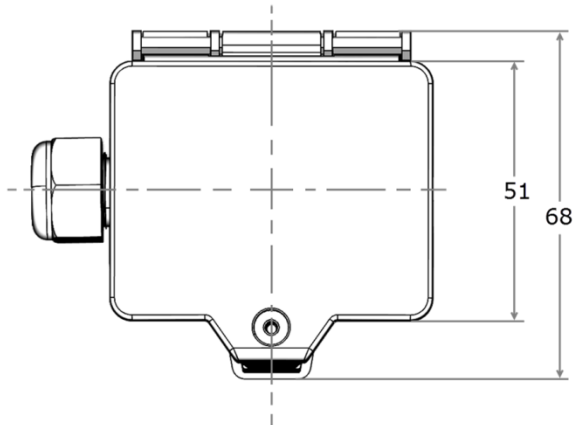

fig. (terminal assignment passive sensor)

Dimensions (mm)



Accessories (optional)

Sealing inserts cable entry (packaging unit 10 pcs.)

Ø	3 mm	5 mm	7 mm	8 mm
Item No.	641036	641012	639248	641340