

» SR07 rH

Wireless room sensor for temperature and rel. humidity

thermokon[®]
HOME OF SENSOR TECHNOLOGY

Datasheet

Subject to technical alteration
Issue date: 21.05.2019 · A100



» APPLICATION

Room temperature sensor radio for room/space applications. Compatible with various design frames (55x55 mm) of different manufacturers. Available in the colours pure white brilliant (standard), aluminium or anthracite.

» SECURITY ADVICE – CAUTION



The installation and assembly of the device should only be performed by authorized personnel.

The product should only be used for the intended application. Unauthorised modifications are prohibited! The product must not be used in relation with any equipment that in case of a failure may threaten, directly or indirectly, human health or life or result in danger to human beings, animals or assets. Ensure all power is disconnected before installing. Do not connect to live/operating equipment.

Please comply with

- Local laws, health & safety regulations, technical standards and regulations
- Condition of the device at the time of installation, to ensure safe installation
- This data sheet and installation manual

» NOTES ON DISPOSAL



As a component of a large-scale fixed installation, Thermokon products are intended to be used permanently as part of a building or a structure at a pre-defined and dedicated location, hence the Waste Electrical and Electronic Act (WEEE) is not applicable. However, most of the products may contain valuable materials that should be recycled and not disposed of as domestic waste. Please note the relevant regulations for local disposal.

» GUIDELINES FOR DEVICES WITH SOLAR ENERGY STORAGE

Due to the energy-optimized EnOcean radio technology used in "EasySens®" wireless sensors, the devices can work without batteries and self-charge themselves using electric energy generated by integrated solar cells. This makes the devices almost maintenance free and environmentally sound due to not having to replace batteries.

For optimum use, the device should be mounted in a location with sufficient ambient brightness. Minimum illumination of 200 lx (artificial light or ambient) is required for at least 3 to 4 hours each day. (The health and safety regulations at work require a minimum illumination of 500 lx for office workplaces).

The solar cell should be mounted facing towards the window direction if possible. If the device has a temperature sensor, then even periodic direct sun radiation should be avoided due to incorrect false temperature readings.

The mounting position should be selected so that the device will not be obstructed in the future: for example by placement areas, additional furniture or roll-fronted cupboards.

The sensor is supplied in an operational state. If the sensor has been stored in darkness for longer periods, the internal solar energy storage will most likely need to be recharged. This would normally happen automatically during commissioning or during initial start up in ambient light. If the initial charge is not sufficient, the sensor will reach its full operating state up to 3 to 4 days, if the requirements for minimum illumination per day are met. The sensor will then transmit continuously in darkness as specified (2/3 days on factory default telegram timing). Depending on the application it is also possible for the devices to operate in darker rooms (with brightness <100 lx) by using the battery back-up option. Batteries to be used are listed in accessories.

The operating time when using batteries will depend on the transmission frequency as well as the component aging and the self-discharge of the battery. Standard operating time will be 5-10 years on factory default telegram timing. Changing of the device from solar to battery operation is done automatically by simply adding a battery to the device.

» REMARKS TO ROOM SENSORS

Location and Accuracy of Room Sensors

The room sensor should be mounted in a suitable location for measuring accurate room temperature. The accuracy of the temperature measurement also depends directly on the temperature dynamics of the wall. It is important, that the back plate is completely flush to the wall so that there is sufficient circulation of air through the vents in the cover, otherwise, deviations in temperature measurement will occur due to uncontrolled air circulation. The temperature sensor should not be covered by furniture or other objects. Mounting next to doors (due to draught) or windows (due to colder outside wall) should be avoided.

Surface and Flush Mounting

The measuring result is influenced by the thermal characteristics of the wall. A solid concrete wall responds to thermal fluctuations within a room in a much slower than a light-weight structure wall. Room temperature sensors installed in flush-mounted boxes have a longer response time to thermal variations. In extreme cases they detect the radiant heat of the wall even if the air temperature in the room is lower for example. The quicker the dynamics of the wall (temperature acceptance of the wall) or the longer the selected inquiry interval of the temperature sensor is the smaller the deviations limited in time are.

» APPLICATION NOTICE FOR HUMIDITY SENSORS

Refrain from touching the sensitive humidity sensor/element. Touching the sensitive surface will void warranty.

For standard environmental conditions re-calibration is recommended once a year to maintain the specified accuracy.

When exposed to high ambient temperature and/or high levels of humidity or presence of aggressive gases (i.e. chlorine, ozone, ammonia) the sensor element may be affected and re-calibration may be required sooner than specified. Re-calibration and deterioration of the humidity sensor due to environmental conditions are not subject of the general warranty.

» INFORMATION ABOUT EASYSSENS® (RADIO) / AIRCONFIG GENERAL USAGE



EasySens® - airConfig

Basic information about EasySens® radio and about general usage of our airConfig software, please download from our website.

» OVERVIEW OF THE RADIO TELEGRAMS



EEP

The structure of the data contained in the telegram can be found in the EEP (EnOcean equipment profile) list provided by the EnOcean Alliance.

» **TECHNICAL DATA**

Measuring values	temperature, humidity
Radio technology	EnOcean (IEC 14543-3-10) EEP A5-04-01
Frequency	868 MHz
Power supply	solar cell, internal super cap, maintenance free, optional: backup battery CR1632
Measuring range temp	0..+40 °C
Measuring range humidity	0..100% rH non-condensing
Accuracy temperature	±0,4 K (typ. at 21 °C)
Accuracy humidity	±5% between 30..70% rH (typ. at 21 °C)
Measuring interval	WakeUp time = 100 sec.
Transmission interval	every 100 sec. at change >0,3 K or >1,6% rH, otherwise every 1000 sec.
Switch ranges Berker	S.1, B.3 aluminium, B.7 glass
Switch ranges Busch-Jaeger	Busch-balance® SI, solo®, future® linear, Busch-axcent®
Switch ranges Gira	E2, Standard 55, Esprit, Event, F100
Switch ranges Jung	A 500, AS 500, A plus, A creation
Switch ranges Merten	M-Smart, M-Arc, M-Plan, M-Pure
Enclosure	PC, pure white, aluminium or anthracite
Protection	IP20 according to EN 60529
Ambient condition	-25..+65 °C, max. 85% rH non-condensing
Weight	45 g
Mounting	to be mounted flat onto the surface using adhesive foil or screws
Delivery content	adhesive foil
Notes	the devices are supplied with an integrated battery backup , for devices with operating elements please refer to product SR07 x

» **PRODUCT TESTING AND CERTIFICATION****Declaration of conformity**

The declaration of conformity of the products can be found on our website <https://www.thermokon.de/>.

» **CRC8 CHECKSUM** (*valid from production date 19140*)

By default, the radio transmitter uses the checksum CRC8 in its telegrams (according to factory setting from 05/2019). This has the advantage that faulty telegrams can be better verified and sorted out on critical radio ranges. Radio receivers older than the TCM3xx only support a simple checksum. In this case, the radio transmitter must be set to simple checksum. To do this, the teach-in button must be pressed 5x consecutively following. The simple checksum is compatible with all receivers. If the transmitter is to be reset to CRC8 checksum, then the learn button must be pressed 3x consecutively.

» MOUNTING ADVICE

(1) Installation is made by gluing the sensor base plate to the smooth wall surface using the adhesive tape included. If required, the base plate can also be fixed by means of raw plugs and screws.

(2) Afterwards, the sensor is clipped onto the base plate (3).

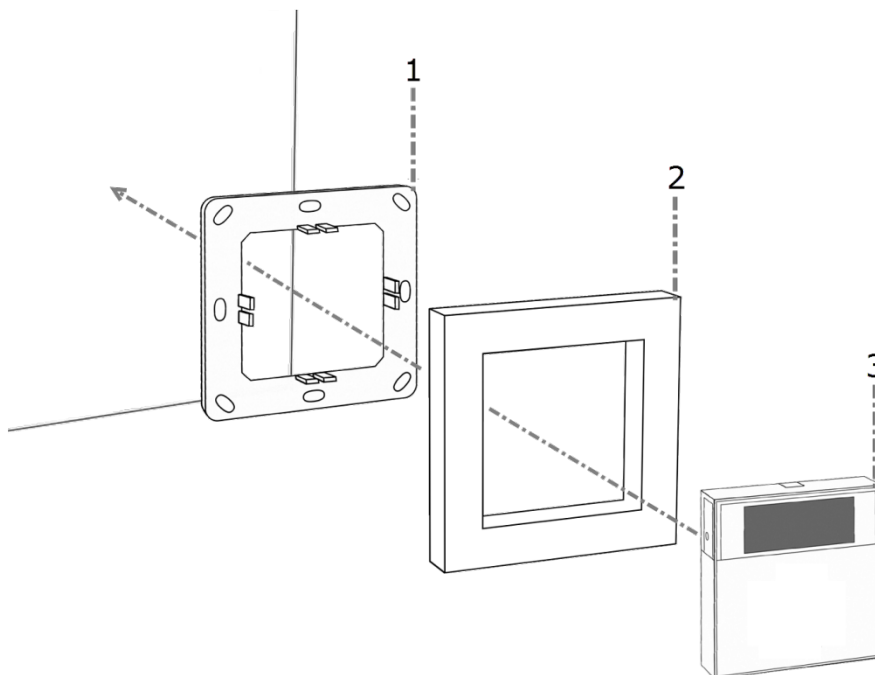

» COMMISSIONING – SHIPPING MODE (valid from production date 19140)

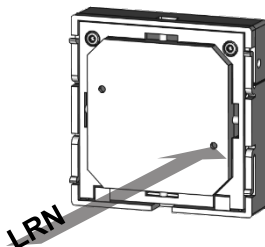

After delivery the room operating unit might be in default shipping mode, in this case press the learn button (<1 second) at the rear of the device [Signal telegramm will be send. SIG -> 0x0F // shipping mode deactivated].

For further shipment, it is possible to set the room operating unit back in default shipping mode. In this case the learn button must be pressed for >3sec [Signal telegramm will be send, SIG -> 0x0E // shipping mode activated].

In order to assure a correct evaluation of the measured values by the receiver, it is necessary to have the devices learned in by the receiver. This is done automatically by means of a "learn button" (LRN) at the sensor or manually by input of the 32bit sensor ID and a special "learning procedure" between sender and receiver. The respective details are described in the corresponding software documentation of the receiver.

The sensor is supplied in an operational status. Probably, the internal solar energy storage must be recharged after a longer storage of the radio sensors in darkness. Basically, the recharging process is done automatically during the first operating hours in daylight. For this purpose, please refer to the remarks "Guidelines for Devices with Solar Energy Storage".

Battery change

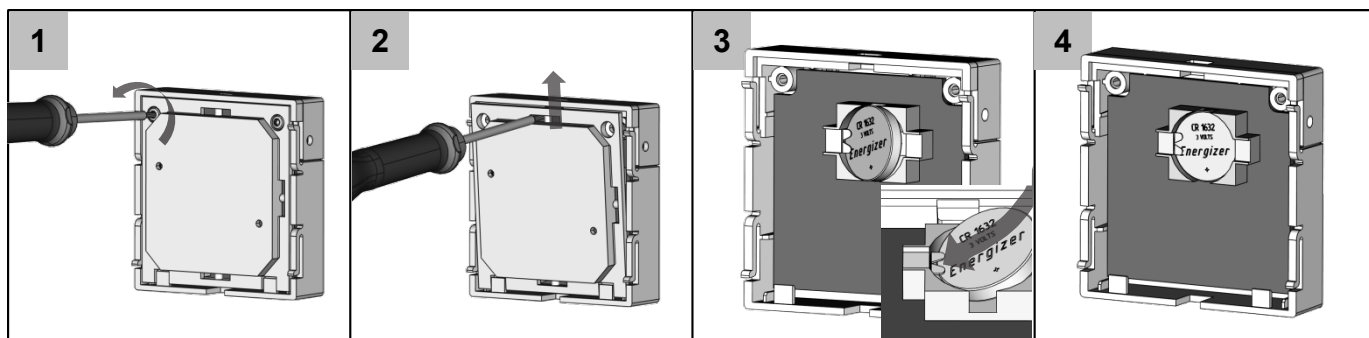

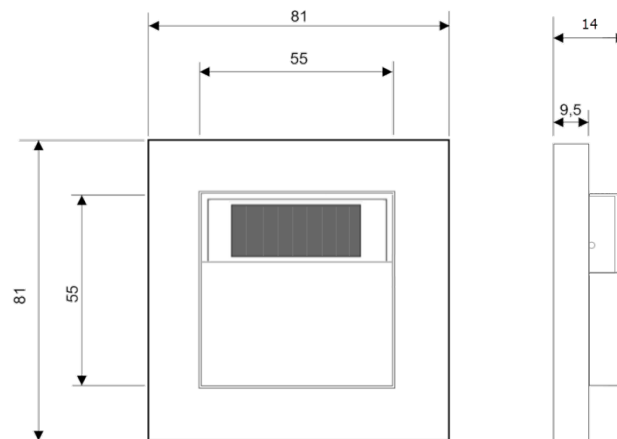
» DIMENSIONS (MM)**SR07 + Gira E2****» ACCESSORIES (OPTIONAL)**

Raw plugs and screws (2 pcs. each)
Battery CR1632
Adhesive foil for fixing the base plate

Item No. 102209
Item No. 597814
Item No. 234726